

# INDEX

## COLLECTIONS

---

|                        |   |         |
|------------------------|---|---------|
| PORCELAIN HAND MADE 3D | 5 | TRILOGY |
|------------------------|---|---------|

---

|                         |    |               |
|-------------------------|----|---------------|
| CERAMIC HANDMADE TILE   | 19 | PATCH         |
| GRES-CLAY HANDMADE TILE | 37 | RR / SQUAR[E] |

---

|                     |    |          |
|---------------------|----|----------|
| WOOD PARQUET SYSTEM | 69 | BLOOMING |
|---------------------|----|----------|

---

|                     |    |                       |
|---------------------|----|-----------------------|
| HANDMADE TERRACOTTA | 75 | LE PIASTRELLE SEGNATE |
|---------------------|----|-----------------------|

---

|                       |     |               |
|-----------------------|-----|---------------|
| CARRARA MARBLE ETCHED | 93  | REGOLI        |
| MODERN MARBLE MOSAIC  | 103 | CONTEMPORAINE |
| CARRARA MARBLE TILES  | 113 | DEPTHILE      |

---

|                     |     |                      |
|---------------------|-----|----------------------|
| CUSTOM MADE SERVICE | 125 | CUSTOM MADE PROJECTS |
|---------------------|-----|----------------------|

---

|                        |     |                         |
|------------------------|-----|-------------------------|
| TIMEWORN MARBLE MOSAIC | 127 | GENUINE ANTIQUED MOSAIC |
|------------------------|-----|-------------------------|

---

|                         |     |  |
|-------------------------|-----|--|
| THE FINE LINES TERRAZZO | 149 |  |
|-------------------------|-----|--|

---

|                         |     |                |
|-------------------------|-----|----------------|
| BLACK TERRACOTTA RUSTIC | 163 | MINIMAL RUSTIC |
|-------------------------|-----|----------------|

---

|                         |     |                             |
|-------------------------|-----|-----------------------------|
| THE MURANO COLLECTION   | 169 | BACKLIT GLASS RELIEF INLAYS |
| ARTWORK WITH MR. LANARO | 205 |                             |

---

|        |     |                    |
|--------|-----|--------------------|
| AWARDS | 217 | BEST OF 2008 -2023 |
|--------|-----|--------------------|

---

|          |     |           |
|----------|-----|-----------|
| DESIGNER | 219 | BIOGRAPHY |
|----------|-----|-----------|



Trilogy Collection, the world's first 3D porcelain Tile Is 2016 Best Of Year INTERIOR DESIGN USA Award Winner on wallcoverings Tile & Stone 3D Category.

This prestigious award is given by the most renowned American magazine called INTERIOR DESIGN. On December 1, 2016 nearly 1,000 people from the design community (designers and manufacturers) gathered at the state-of-the-art Frank Gehry design, IAC Building in New York City.

Trilogy Collection on May 2017 at Museum of Modern Art in New York City won a 2nd Award as best covering tile at INTERIOR DESIGN Magazine event during the New York City Design Week.



## THE WORLD'S FIRST REAL 3D PORCELAIN TILES

Trilogy by Giovanni Barbieri is an utterly unique product with the following characteristics:

The world's first three-dimensional porcelain tile measuring 2" deep hexagonal 6" ( cm 15,0 ) side changing its surface thickness from 1/4 to 1" 2/3" ( 8 mm to 45 mm ) in just 11" 4/5 ( 30 cm ) which represents the largest side of each tile.

This is also the first pattern where a regular hexagonal tile, ease of installation, obtains irregular random shapes thanks to two different joint widths generated during installation.

The fashionable combination of the 3 different textures applied on 3 different color shades in 3 different ways on 3 different models, which need to be installed randomly, complete the latest barbieri utterly unique aesthetic result.

The 3 models permit to obtain on linear pattern and one random pattern installation.

Individual custom accents are available on depth, colours and textures including corners and frame accessories thanks to the customer service of Barbieri design studio.

A new concept of background or just ornamental wall solution in between a traditional flat surface and high structured 3d walls.

Offering an easy maintenance / cleaning surface, also suitable for any lighting and installation accessories.

Guaranteed for any exterior extreme climate condition, wet area installation or next to high- temperature sources (fireplace wall).



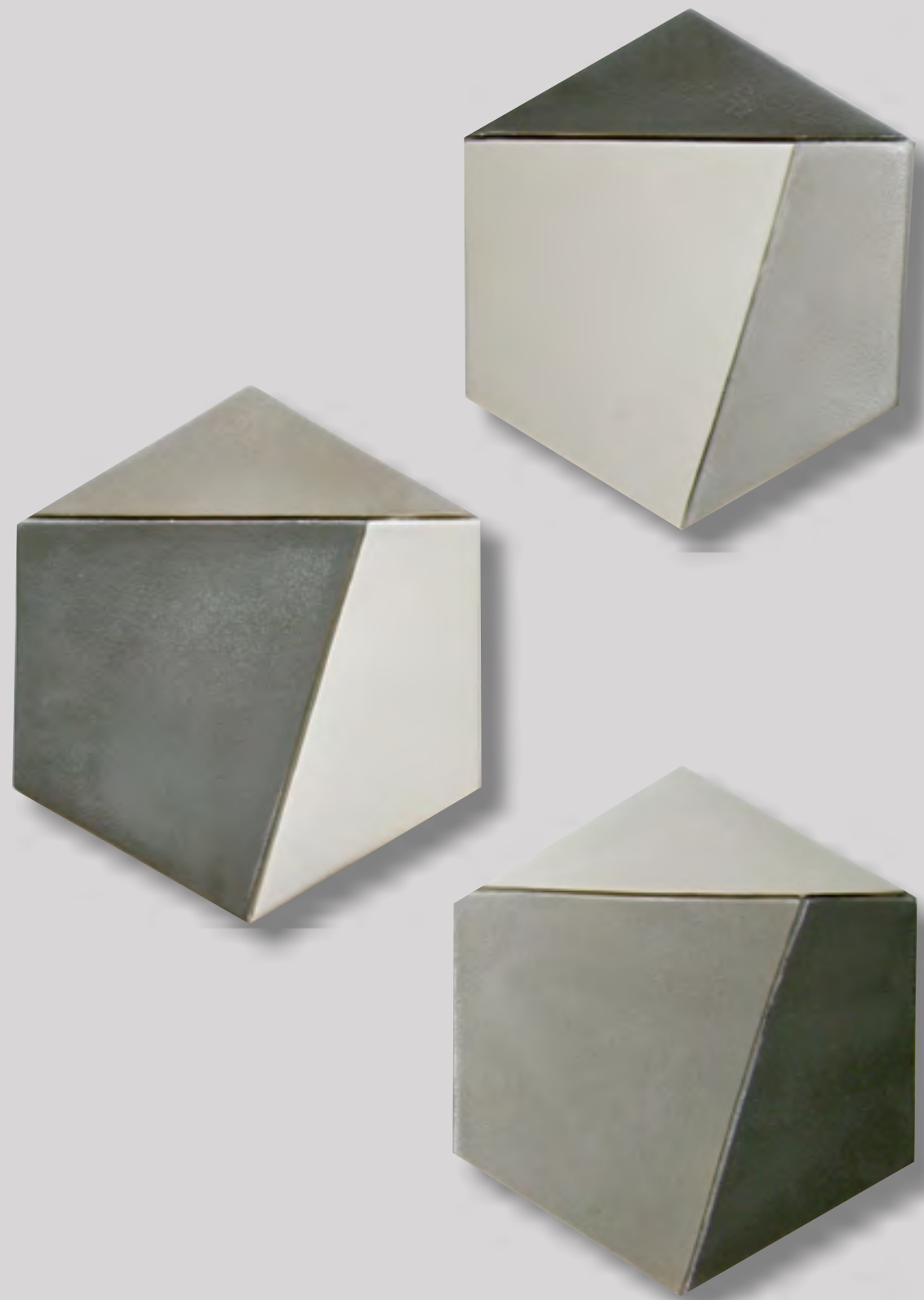

THE FASHIONABLE COMBINATION OF THE 3 DIFFERENT TEXTURES APPLIED ON 3 DIFFERENT COLOR SHADES IN 3 DIFFERENT WAYS ON 3 DIFFERENT MODELS, WHICH NEED TO BE INSTALLED RANDOMLY, COMPLETE THE GIOVANNI BARBIERI UTTERLY UNIQUE AESTHETIC RESULT.

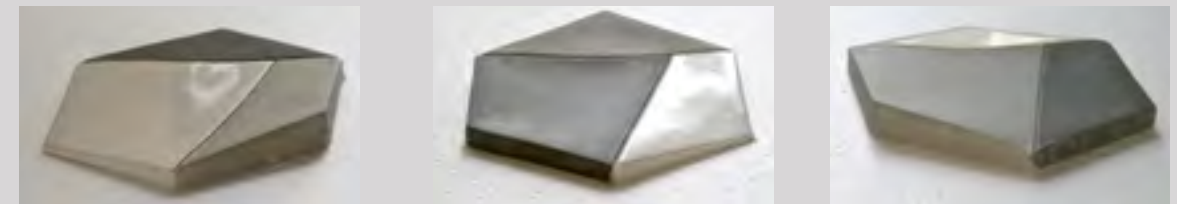

THE WORLD'S FIRST THREE-DIMENSIONAL PORCELAIN TILE MEASURING 1" 1/2 DEEP HEXAGONAL 6" (15,0 CM) SIDE CHANGING ITS SURFACE THICKNESS FROM 2/8 TO 1\_1/2" (8 MM TO 38 MM) IN JUST 11" 3/8 (30,0 CM) WHICH REPRESENTS THE LARGEST SIDE OF EACH TILE.

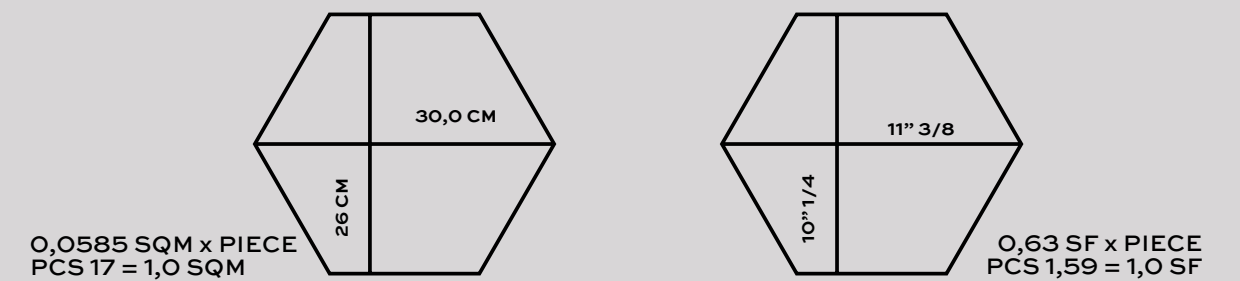

ALL 3 MODELS/TILES HAVE 3 TO 4 MM JOINT IN THE MIDDLE BETWEEN THE 3 SHAPES COMPOSING EACH SINGLE TILE. DURING INSTALATION, SIMPLY ALIGN THE EDGE OF ONE TILE TO THE MATCHING ( SAME LENGTHS THICKNESS ) EDGE OF THE ADJACENT TILE. THIS ALLOWS A SINGLE COLOR AND TEXTURE TO COME TOGETHER, WHILE BEING DEFINED BY THE PERIMETRAL LARGER JOINT.



Double pattern installation

## TWO PATTERNS ON SAME WALL

Allows seamless adaptation  
to individual preferences.





ULTRA WHITE



ULTRA WHITE

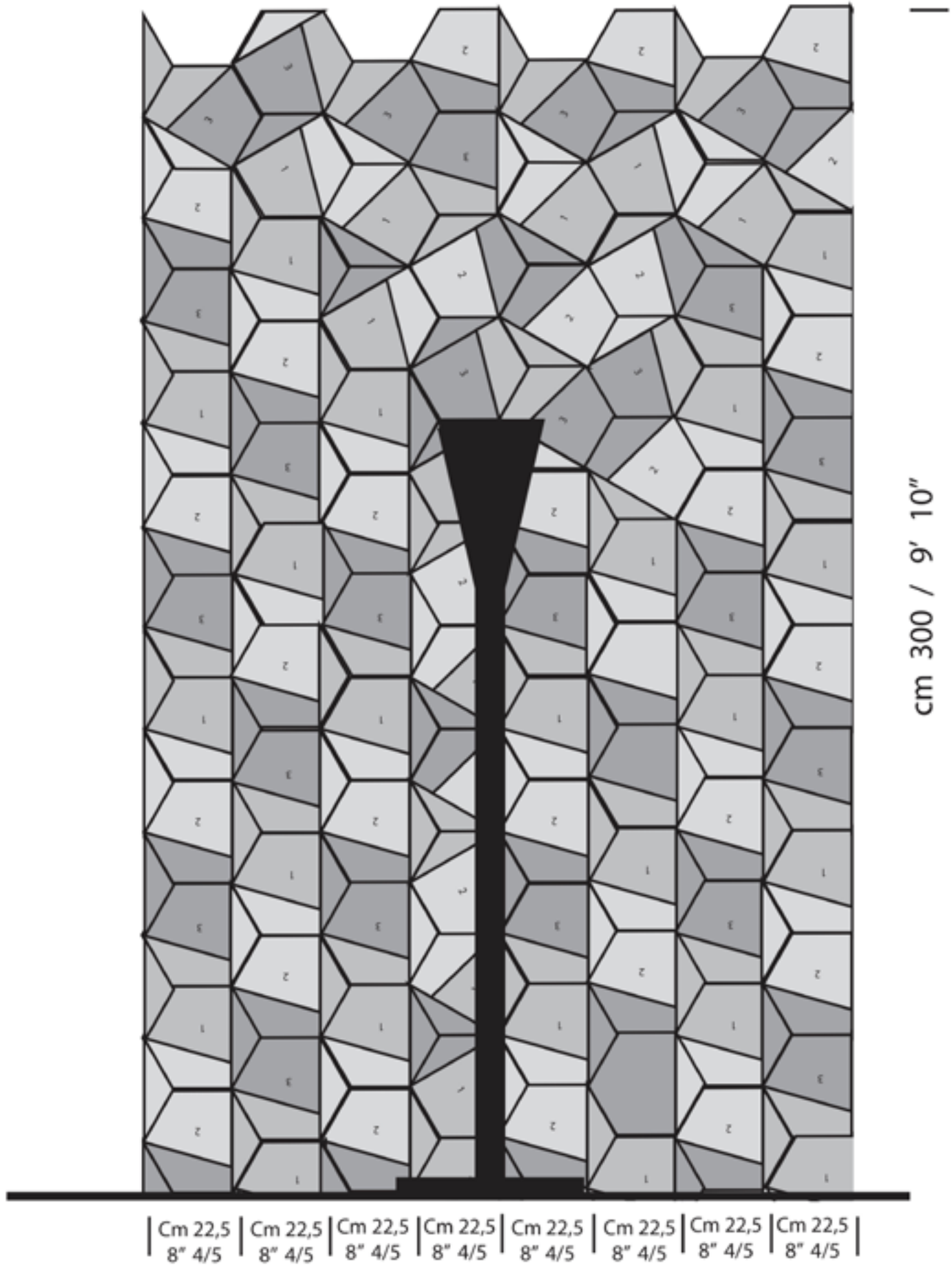

KONA



45 cm / 17" 6/8

45 cm / 17" 6/8

45 cm / 17" 6/8

135 Cm / 53"







**PATCH COLLECTION**  
HANDMADE VENETIAN CERAMIC TILE

A TILE WITH A GENUINE FEELING,  
WHERE CRAFTSMANSHIP IS HIGHLIGHTED,  
WITH A LIVELY DESIGN,  
NEVER UNIFORM  
AND HARMONIOUS IN ITS OWN WAY.



PATCH COLLECTION IS A COMBINATION OF RESEARCH & DEVELOPMENT OF GEOMETRIC NEW TILE SHAPES, SURFACE TEXTURE AND COLOUR COMBINATIONS, PRODUCTION FEASIBILITY AND PARTICULARLY GREAT AESTHETIC RESULTS.

PATCH IS 5" 2/3 X 5" 1/3 X 3/8 HANDMADE TOTALLY NEW LOOK OF CERAMIC TILES AS NEVER SEEN BEFORE: THE PURELY RANDOM INSTALLATION OF THE DIFFERENT MODELS OBTAIN A PLAY OF DEFORMED SQUARE SHAPES THAT ARE ALWAYS DIFFERENT, WITH NO COMPARE.

# SHAPE AND MODELS

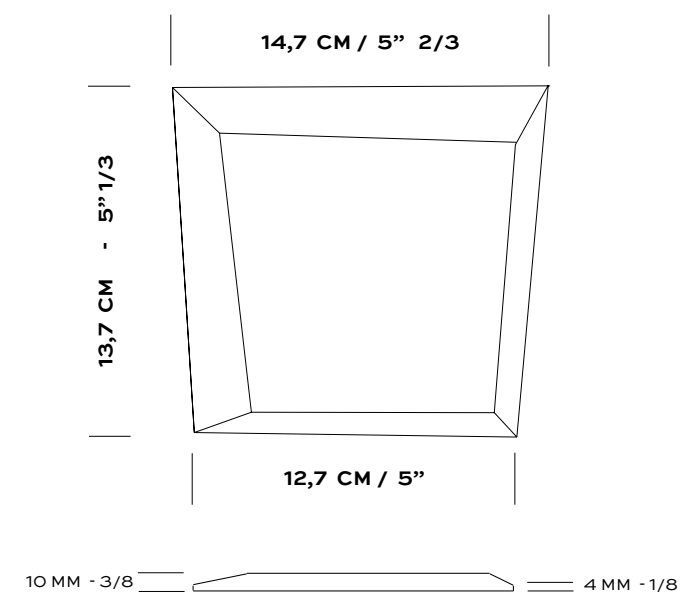

PCS 5 = 1,0 SF  
PCS 53,5 = 1,00 SQM

8 DIFFERENT MODELS

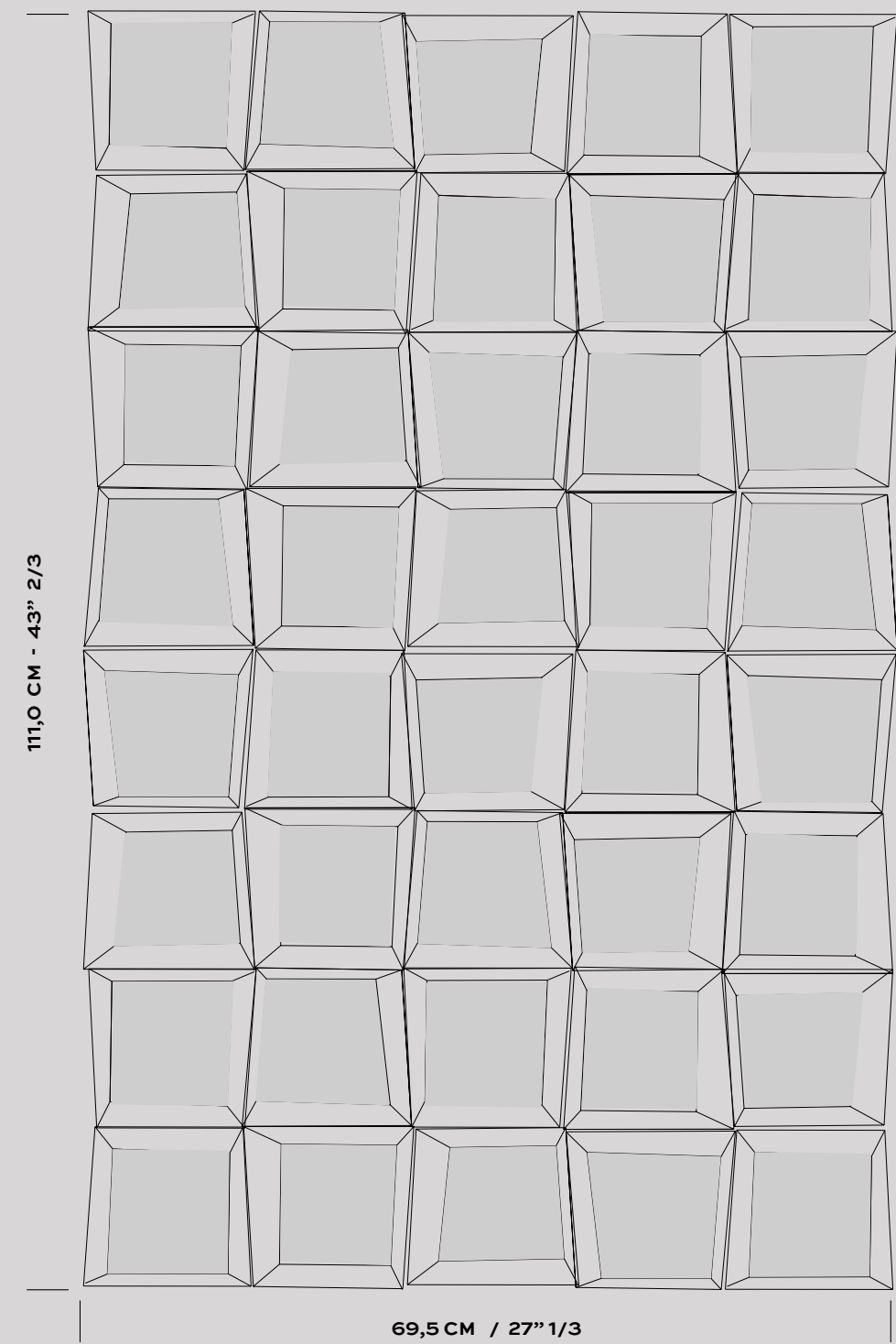

STANDARD COLOURWAYS



#1 PATCH GLOSSY WHITE  
TEXTURED BEIGE SIDES.



#2 PATCH GLOSSY WHITE  
SMOOTH BLACK SIDES.



#3 PATCH SMOOTH DARK GREY  
TEXTURED BEIGE SIDES.

#1



GLOSSY WHITE  
TEXTURED  
BEIGE SIDES

#2



GLOSSY WHITE  
SMOOTH  
BLACK SIDES

#3

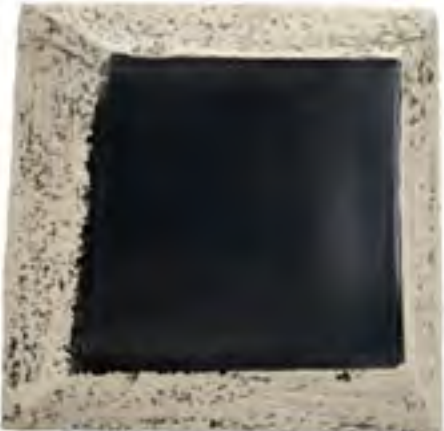

SMOOTH DARK GREY  
TEXTURED  
BEIGE SIDES.





#1 WHITE - BEIGE



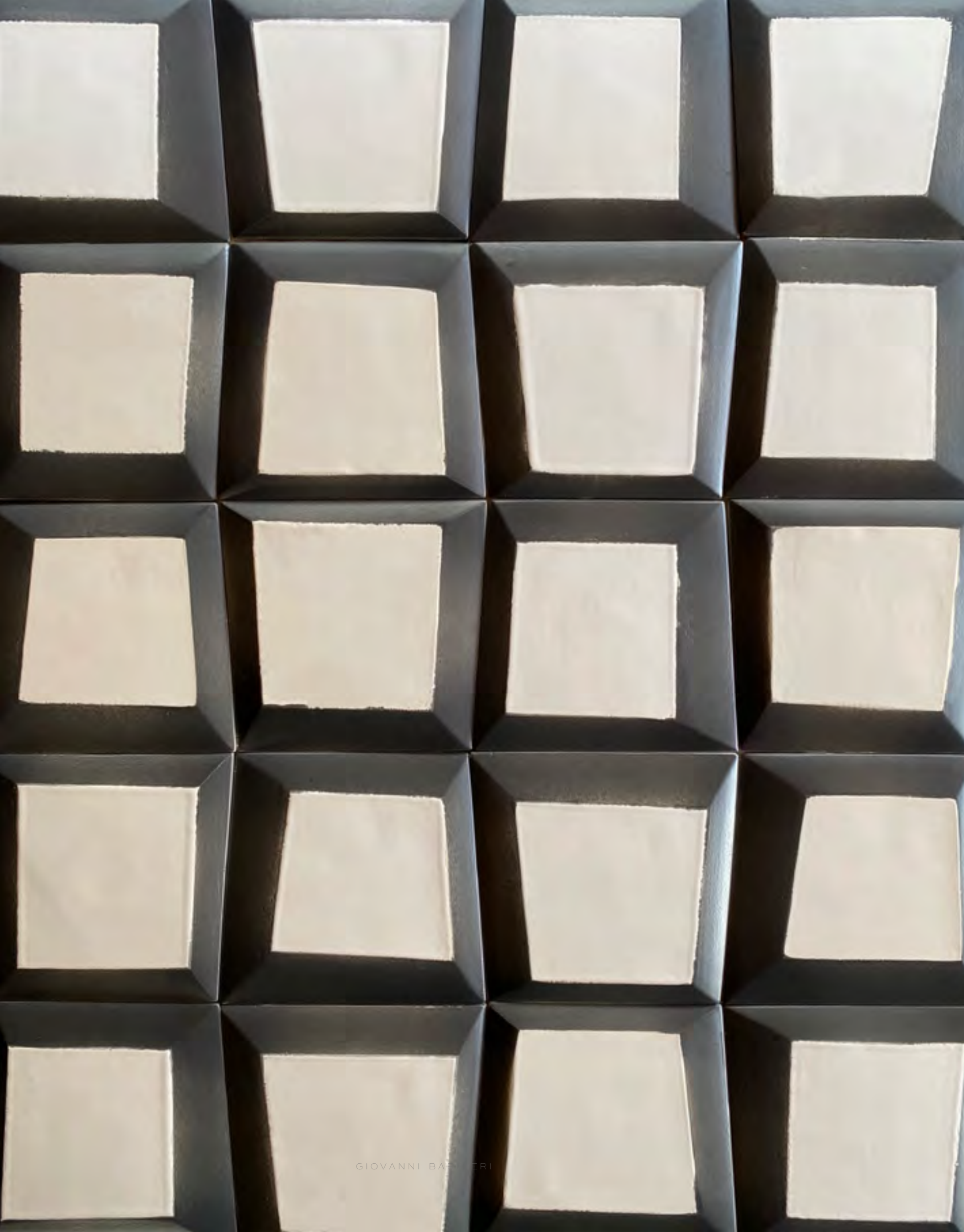

#2 WHITE - BLACK





#3 DARK GREY - BEIGE





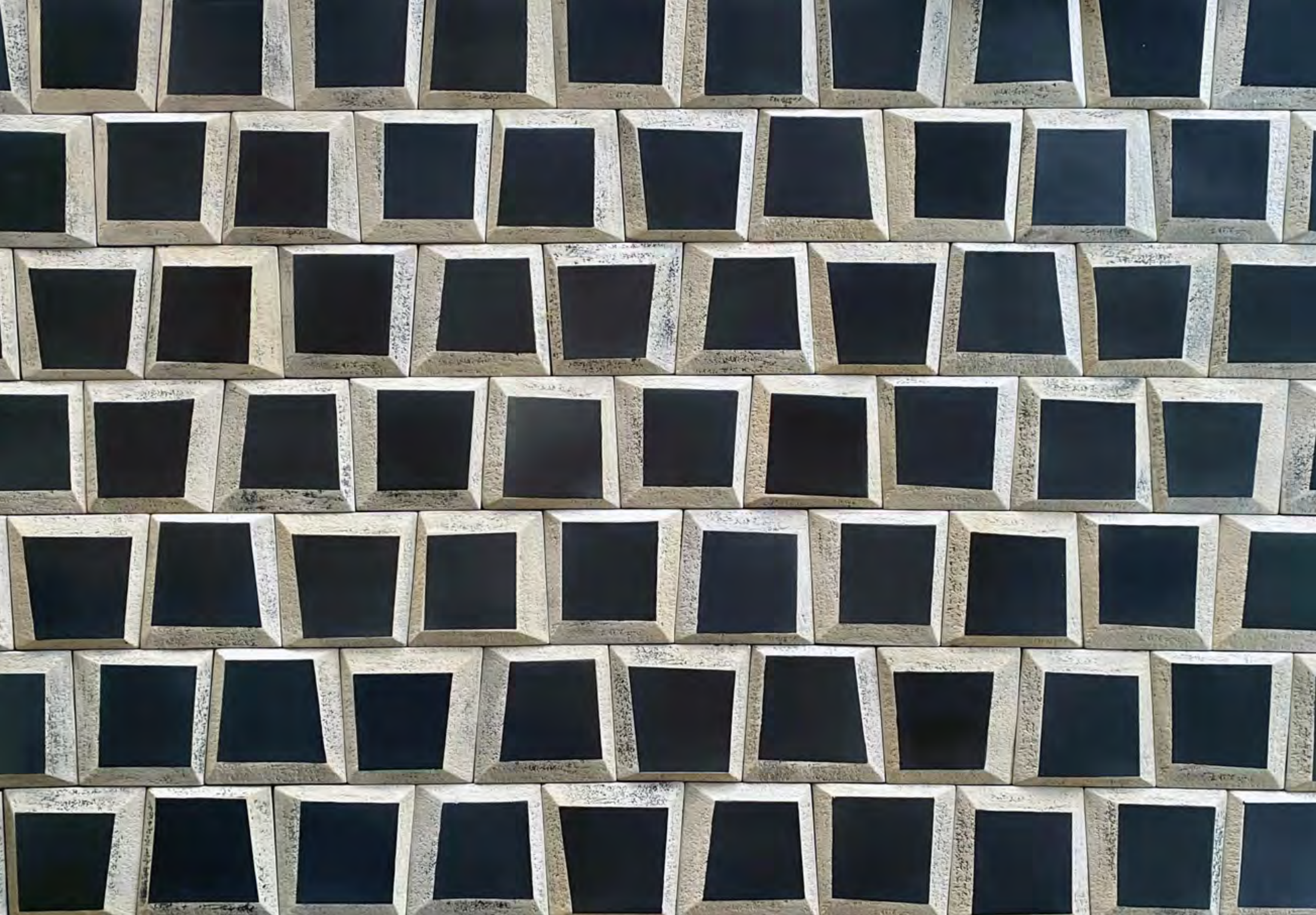

#4 ALL MODELS MIXED

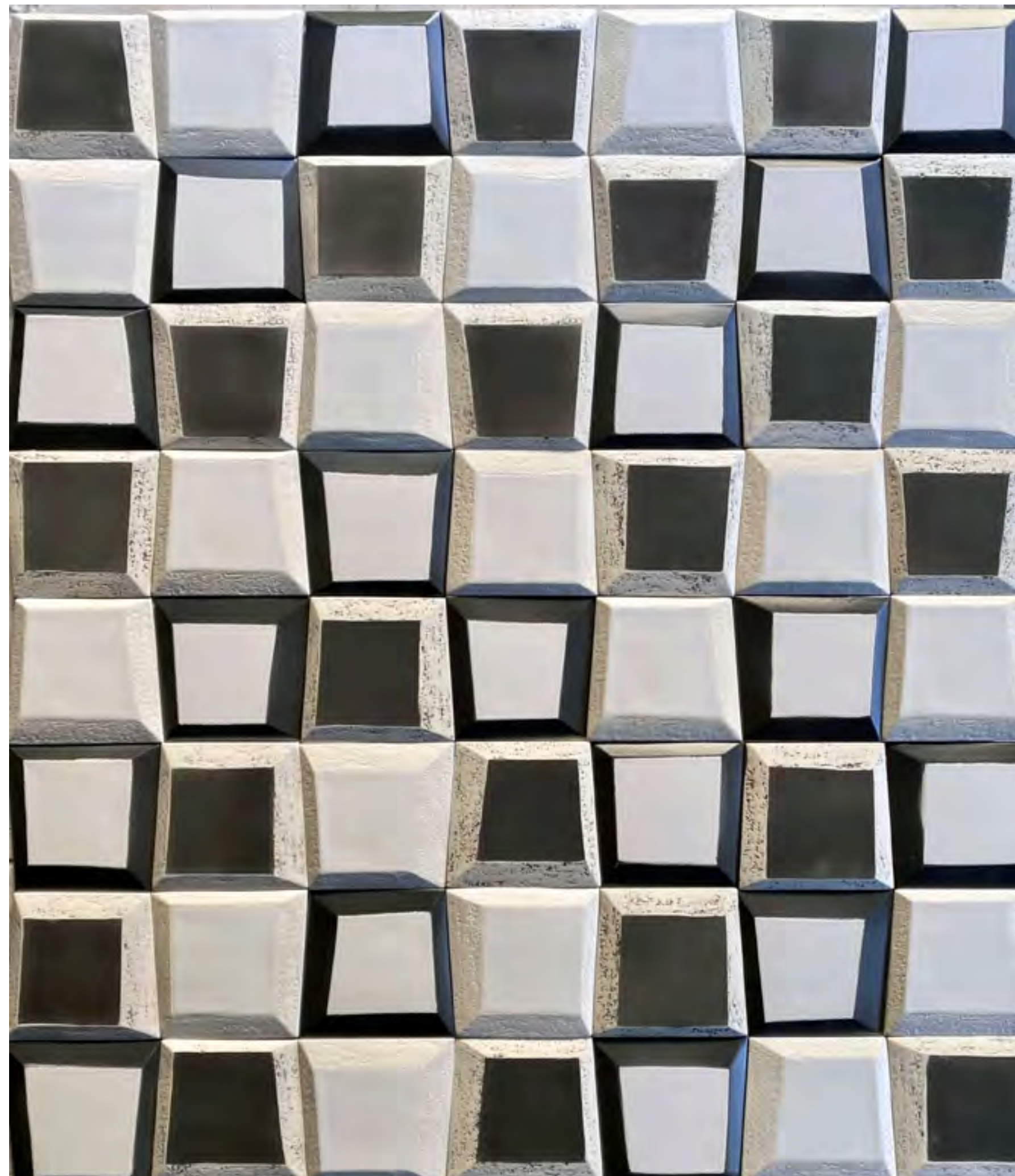

CARVED & CONVEX HANDCRAFTED GRÉS TILES.

THE VENETIAN ARTISAN TRADITION  
NOW ALLOWS SEAMLESS ADAPTATION  
TO INDIVIDUAL PREFERENCES.

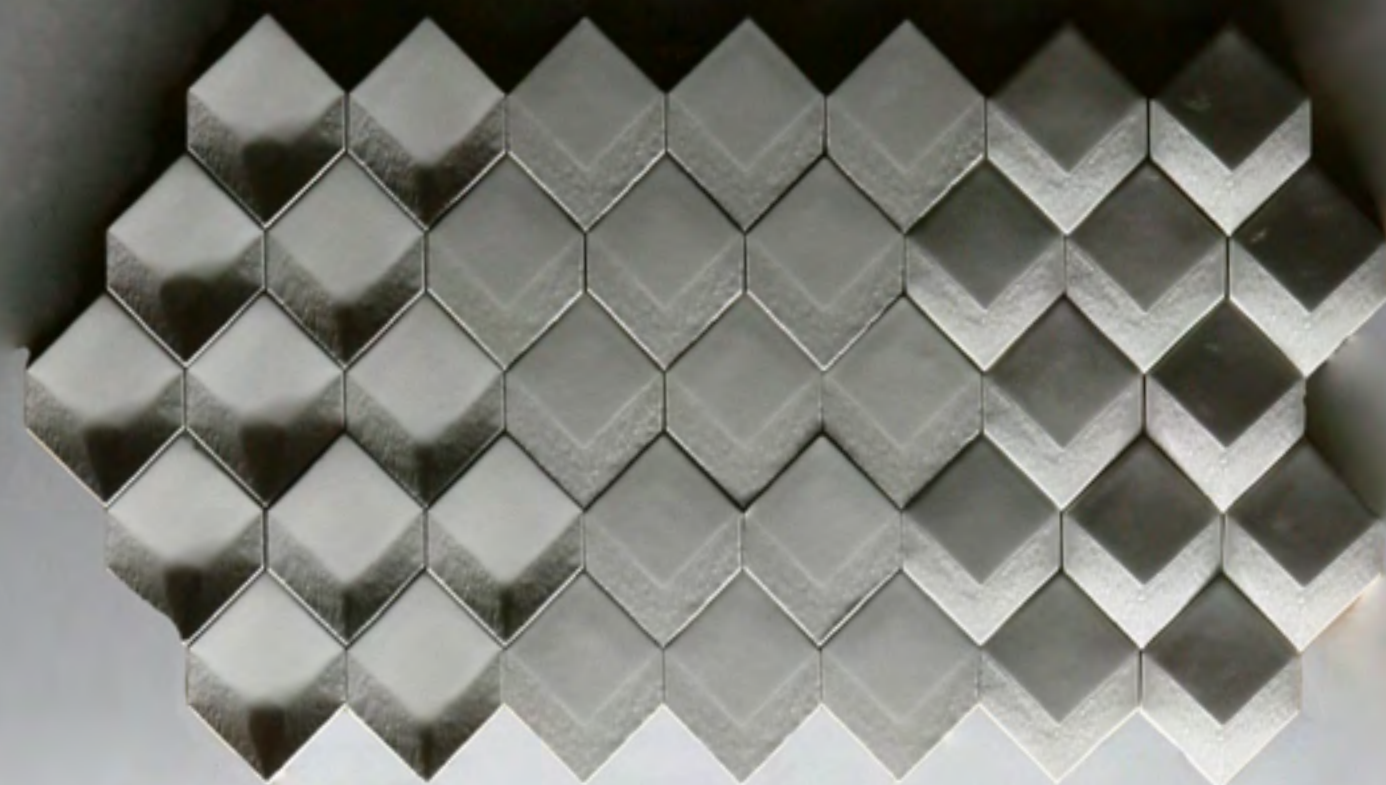

## DIMENSIONS

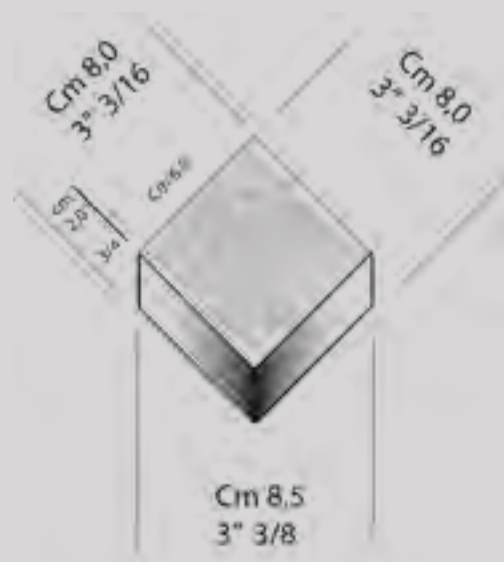

**EACH MESH MOUNTED PANEL IS COMPOSED WITH 15 TILES:**

SURFACE CM 36,0 X 25,5 = MQ 0,092 EACH PANEL

SURFACE 14" 3/16 X 10" = SF 0,99 EACH PANEL

SHADING WALLS  
FROM FLAT TO LOW HIGH CARVED-CONVEX TILES  
IN 5 MODELS



FLAT



1  
MEDIUM  
CARVED



2  
MAX  
CARVED



3  
MEDIUM  
CONVEX



4  
MAX  
CONVEX

AVAILABLE IN CERAMIC TILE HONED OR POLISHED SURFACE  
WITH HAND PAINTED CUSTOMIZABLE OPTIONS.

PLASTER IS ALSO AVAILABLE FOR  
DRY INSTALLATION/DESTINATION USE, ONLY,  
EXCLUSIVELY PRODUCED BY STAFFDECOR.FR IN FRANCE.

FOR EXTERIOR USE, AND WET AREA INSTALLATION  
A GRES VERSION IS AVAILABLE IN SIZE 7,5X7,5 CM ( 3" X 3").

**EACH MESH MOUNTED PANEL IS COMPOSED WITH 15 TILES:**

SURFACE 33,6 X 23,3 CM = MQ 0,0783 EACH PANEL

SURFACE 13" 1/6 X 9" 1/6 = SQ. FT. 0,842 EACH PANEL

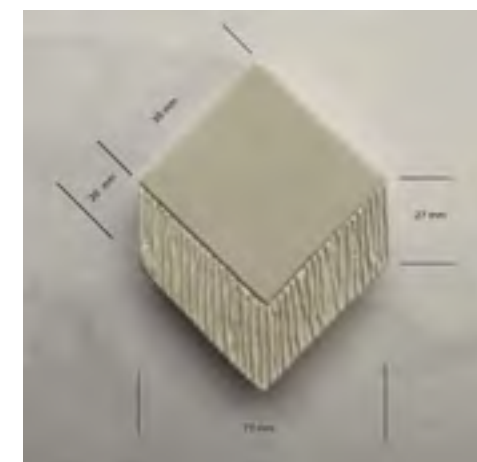

SUPPLIED AS LOOSE TILES OR MESH MOUNTED  
FOLLOWING A LAY OUT DRAWING INSTALLATION.

## PROJECT EXAMPLE

THE PERFECTLY THOUGHT-THROUGH DESIGN  
IS ALSO HIGHLY FUNCTIONAL IN TERMS OF INSTALLATION  
AND ALLOWS SEAMLESS ADAPTATION TO INDIVIDUAL PREFERENCES.



PATTERN 1  
FLAT TILE ONLY



PATTERN 2  
FLAT & MEDIUM  
CARVED/CONVEX

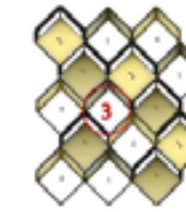

PATTERN 3  
MAX & MEDIUM  
CARVED/CONVEX



PATTERN 4  
MAX  
CARVED/CONVEX

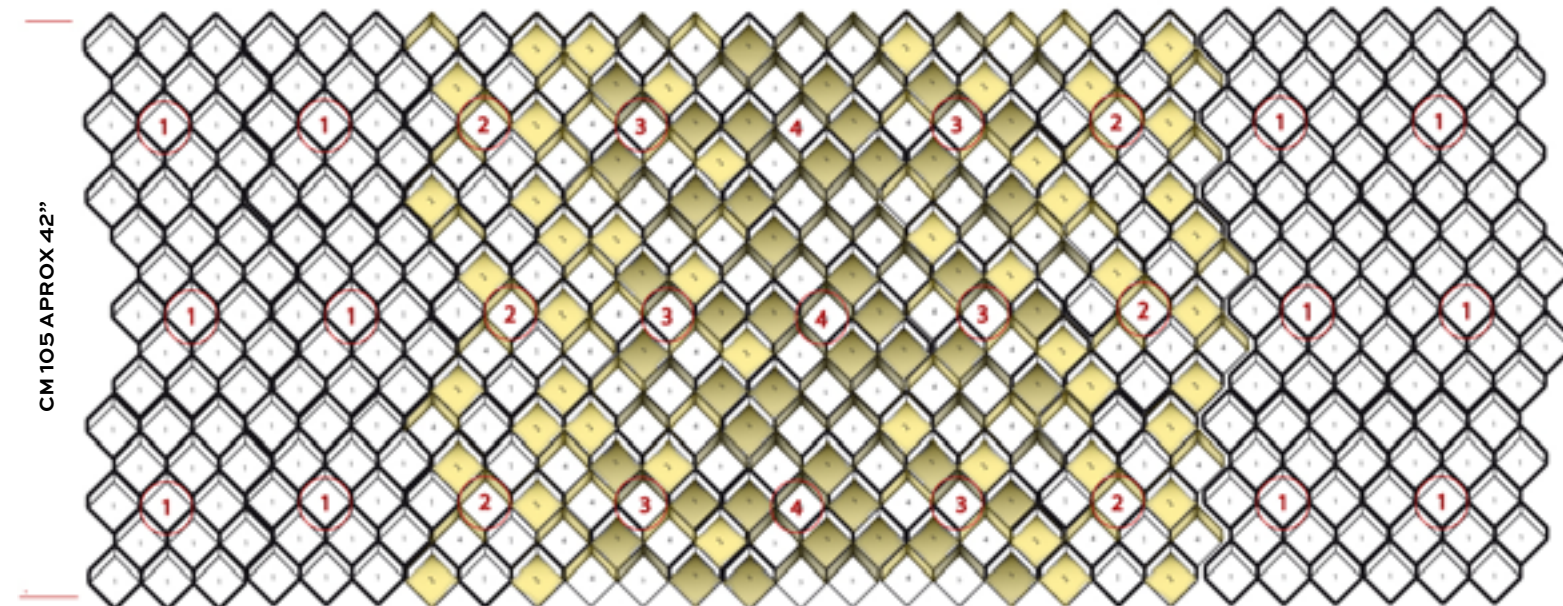

**PATTERN INCLUDING  
ALL THE 4 MODELS**

THE RESULTING STRUCTURES HAVE A HIGHLY IMPRESSIVE EFFECT,  
ESPECIALLY ON LARGE SURFACES,  
AND CREATE DISTINCTIVE ATMOSPHERES IN INTERIORS.



**PATTERN 4  
MAX  
CARVED/CONVEX**



**PATTERN 3  
FLAT & MEDIUM  
CARVED/CONVEX**



**PATTERN 2  
FLAT & MEDIUM  
CARVED/CONVEX**

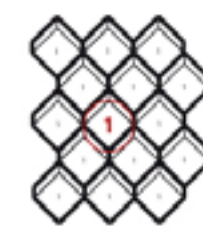

**PATTERN 1  
FLAT TILE ONLY**

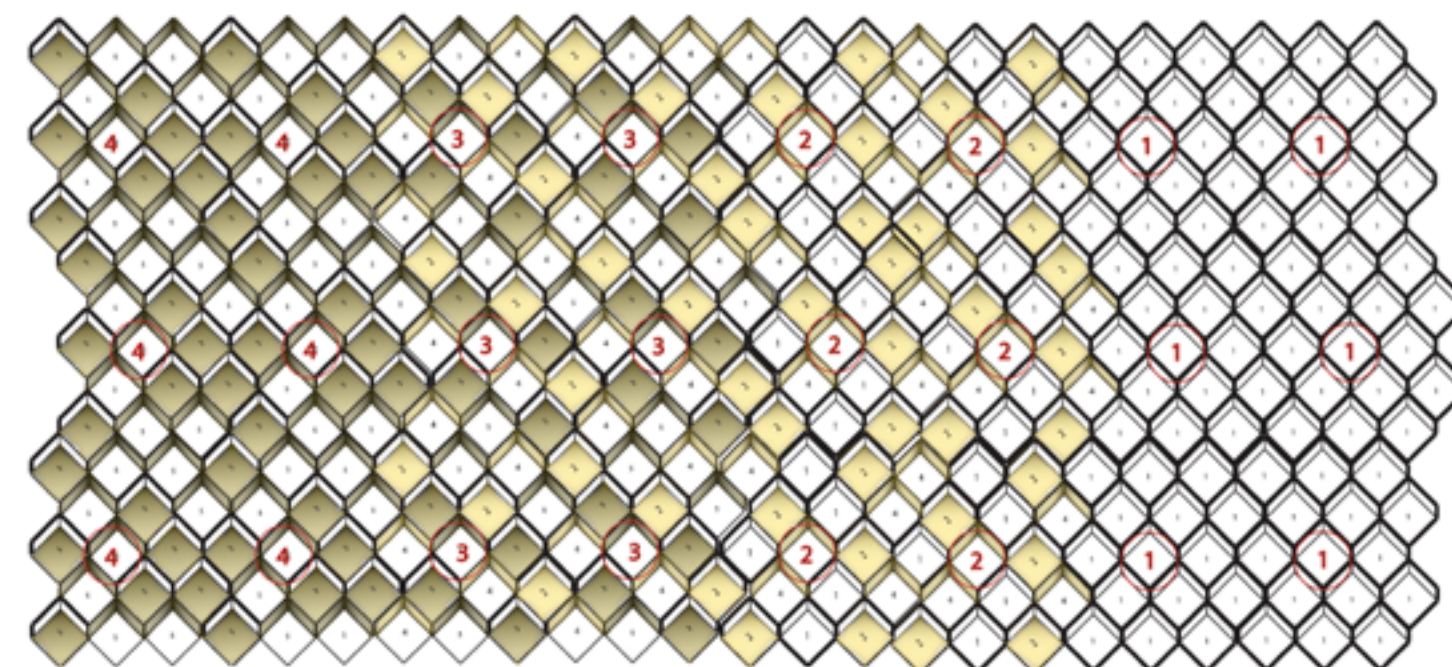
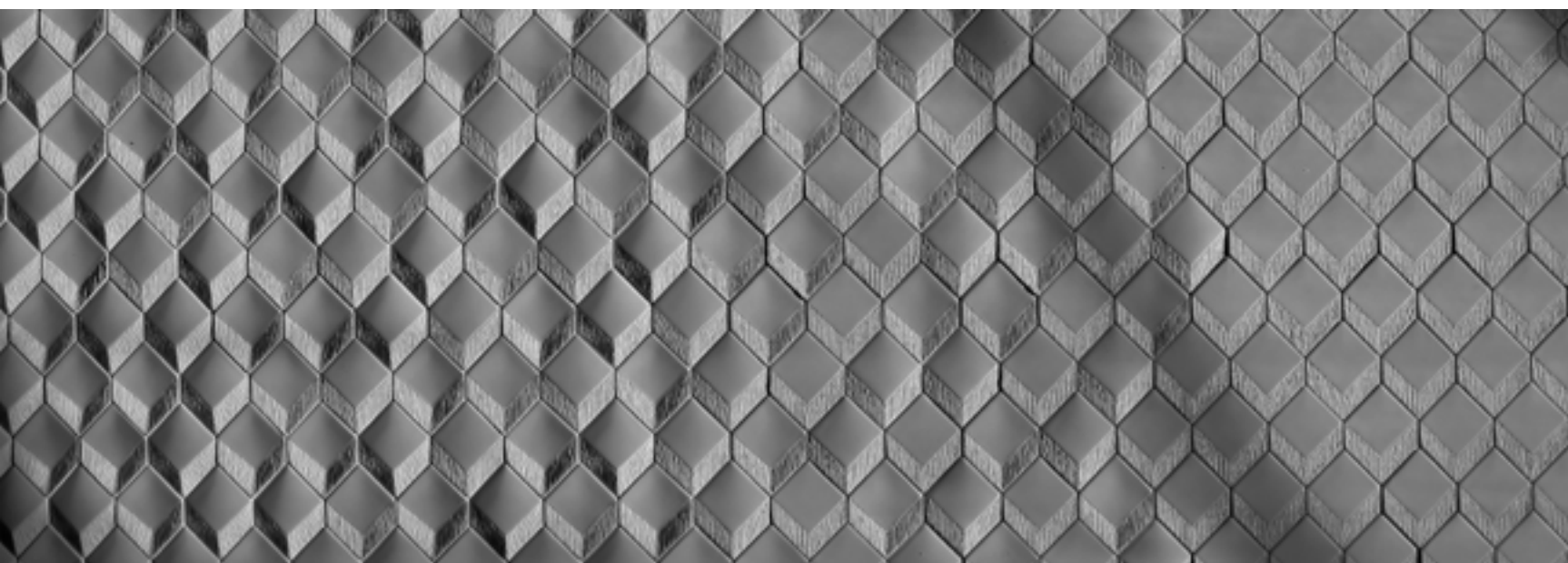



THE MORE DETAILED IN THE INFORMATION REQUEST FIELD THE BETTER.

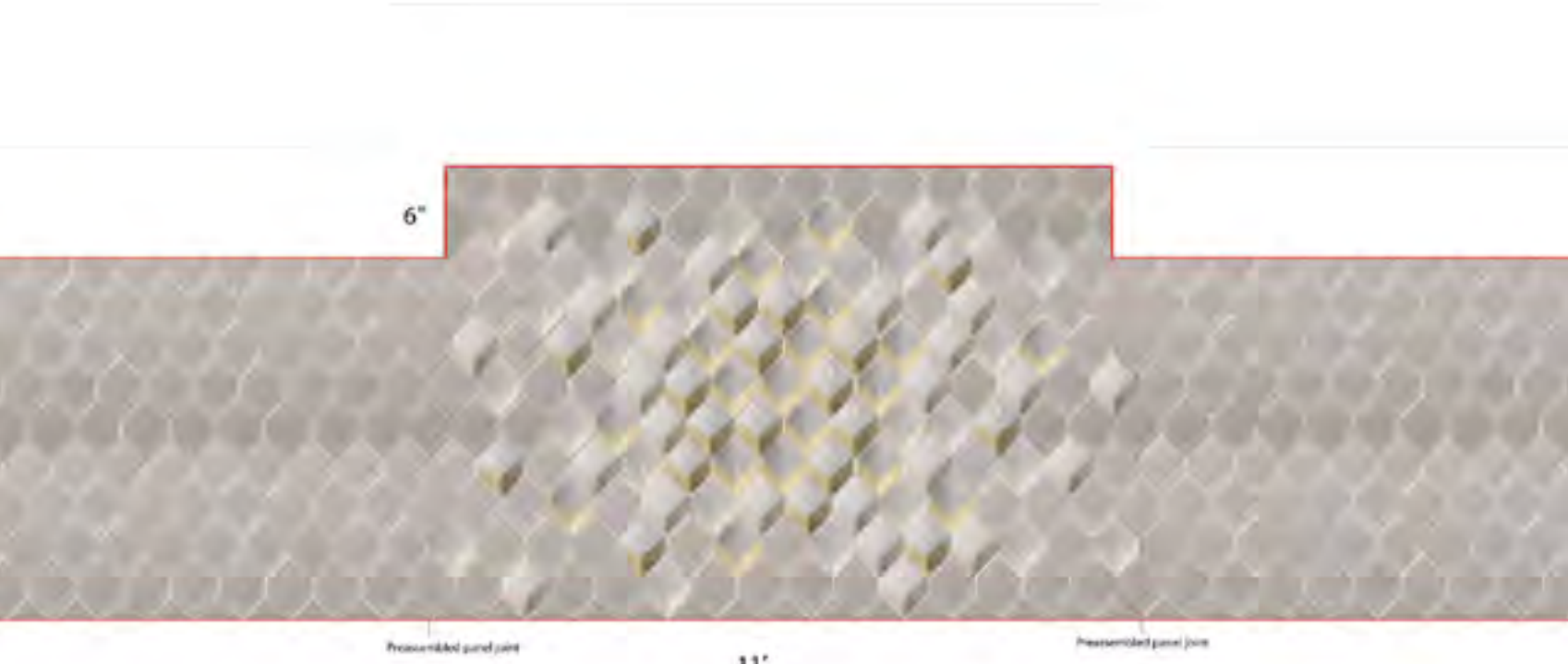

RR Collection Ceramic Tile installed on 3 preassembled panels , grouted not included ( supplied separately inside the shipped crate )  
 Background colour would be at Customer choice: white is best suggestion from us.

-   
 FLAT  
 pcs 366
-   
 Low carved  
 low gold density  
 pcs 25
-   
 Low convex  
 low gold density  
 pcs 25
-   
 High Carved  
 gold  
 pcs 18
-   
 High Convex  
 gold  
 pcs 20

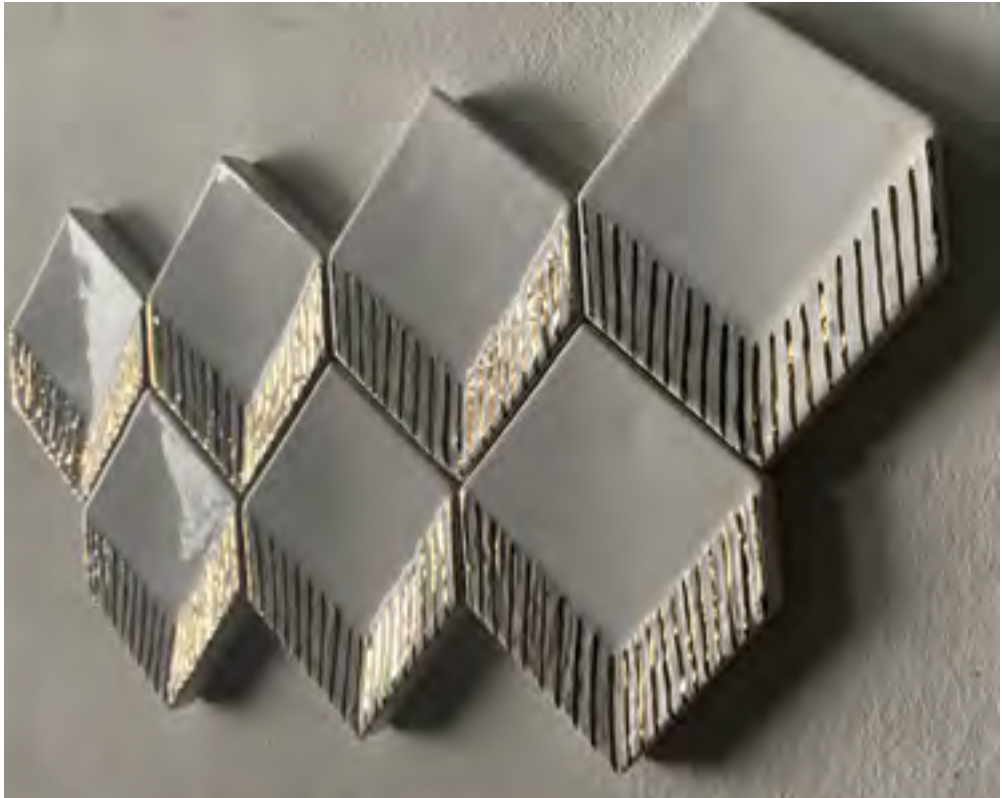
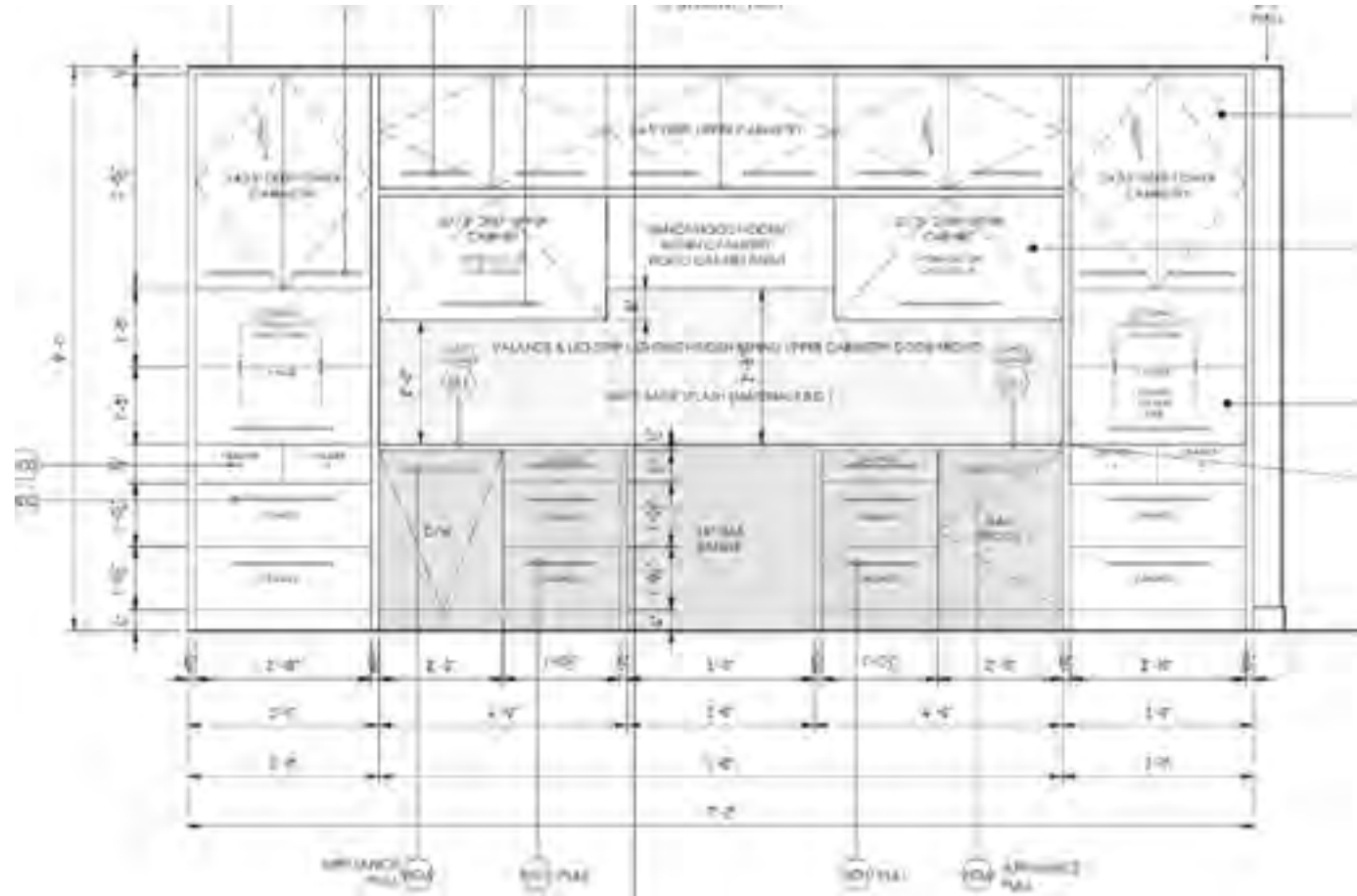



“SQUAR[E] COLLECTION GIVES DESIGNERS A BUDGET-FRIENDLY WAY TO CREATE ARTISTIC INSTALLATIONS, THAT PROGRESS FROM FLAT TO 3D AND FROM SQUARE TO IRREGULAR SHAPES USING A SINGLE PRODUCT.”

ARCHITECTURAL RECORD USA MAGAZINE,  
AWARDED SQUAR SIZE 4” X 5” ENGINEERED MARBLE ORIGINAL 2018 VERSION  
AS 1 OF 8 BEST SURFACING PRODUCTS OF THE YEAR

**ARCHITECTURAL  
RECORD**

THE ORIGINAL SQUAR IS 2018 BEST OF YEAR INTERIOR DESIGN USA  
HONOREE AWARD WINNER IN  
AMERICAN MAGAZINE INTERIOR DESIGN.  
ON MAY 2019, AT PIER 17 JUST REBUILT IN  
NEW YORK, SQUAR WON THE 2ND HONOREE AWARD AS 1 OF THE 4  
BEST WALL COVERINGS PRODUCTS  
WITH DESIGNER COOPERATION,  
AT THE INTERIOR DESIGN MAGAZINE EVENT  
DURING THE NEW YORK CITY DESIGN WEEK.



**reddot winner 2021**

MARCH 2021

THE “RED DOT” IS THE AWARD FOR HIGH DESIGN QUALITY. THE INTERNATIONAL JURY ONLY AWARDS THIS SOUGHT-AFTER SEAL OF QUALITY TO PRODUCTS THAT FEATURE AN OUTSTANDING DESIGN.

Professor Dr. Peter Zec  
Founder and CEO of Red Dot

# SQUAR[E]

DIMENSIONAL TILES

FOR THE FIRST TIME,  
A TILE COLLECTION THAT SEAMLESSLY BLENDS FROM  
A FLAT TO A FULLY 3 DIMENSIONAL TEXTURE  
AND FROM SQUARED, REGULAR SHAPES,  
TO A RANDOM PATTERN OF SHAPES .

NOW AVAILABLE IN  
WET PRESSED, HAND-PAINTED CERAMIC VERSION

NEW SIZE OF 2” X 2” 1/4

9 STANDARD PATTERNS  
AND  
INFINITIVE CUSTOM MADE INTERPRETATIONS FOR YOUR PROJECT

MORE LIKE AN ART PERFORMANCE THAN JUST A TILE PROJECT.

SURFACE ARCHITECTURE  
EXPANDS ITS LIMITS  
WITH THE NEW  
SQUAR[E] COLLECTION.

SQUAR[E] MODIFIES YOUR WALL  
AND MAKES IT FREE, AVAILABLE  
TO CHANGES OF DIRECTION AND SHADES  
WITH A MULTIPLICITY OF INTERPRETATIONS.  
THUS A NEW FACT HAPPENS.



reddot winner 2021



# INSTALLATION EXAMPLE



48 1/2" - 123 CM

41" - 105 CM

# COLORS



BIANCO  
MATT



GRIGIO  
CHIARO

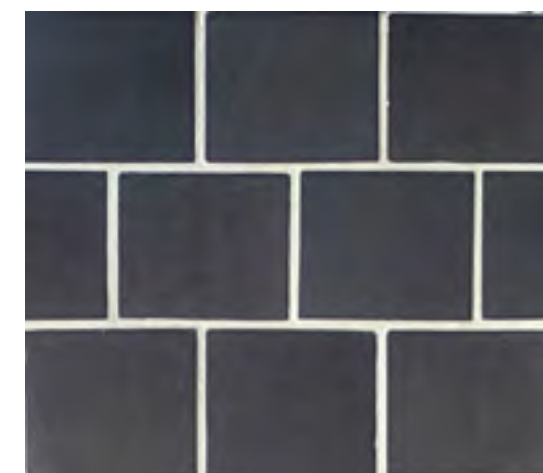

GRIGIO  
SCURO

WE SUPPLY THE CLOSEST CUSTOM  
MADE COLOUR POSSIBLE TO YOUR  
REQUEST FOR FINAL APPROVAL  
BEFORE PRODUCTION STARTS.

## DIMENSIONS

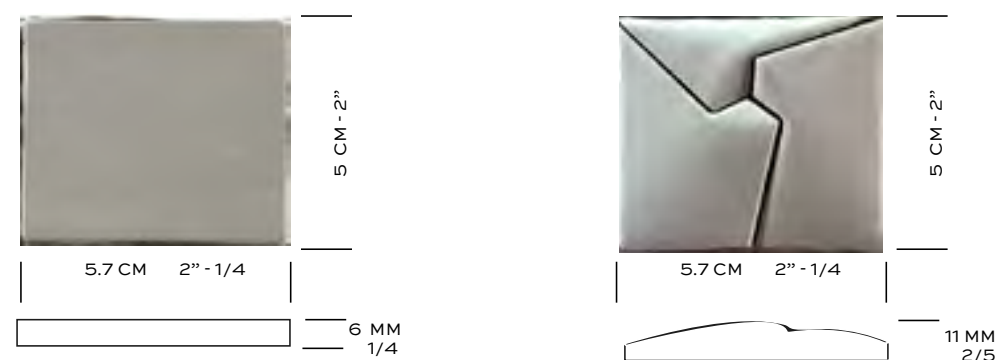

## INSTALLATION EXAMPLE



55'' - 1/2 - 141 CM

41'' - 105 CM

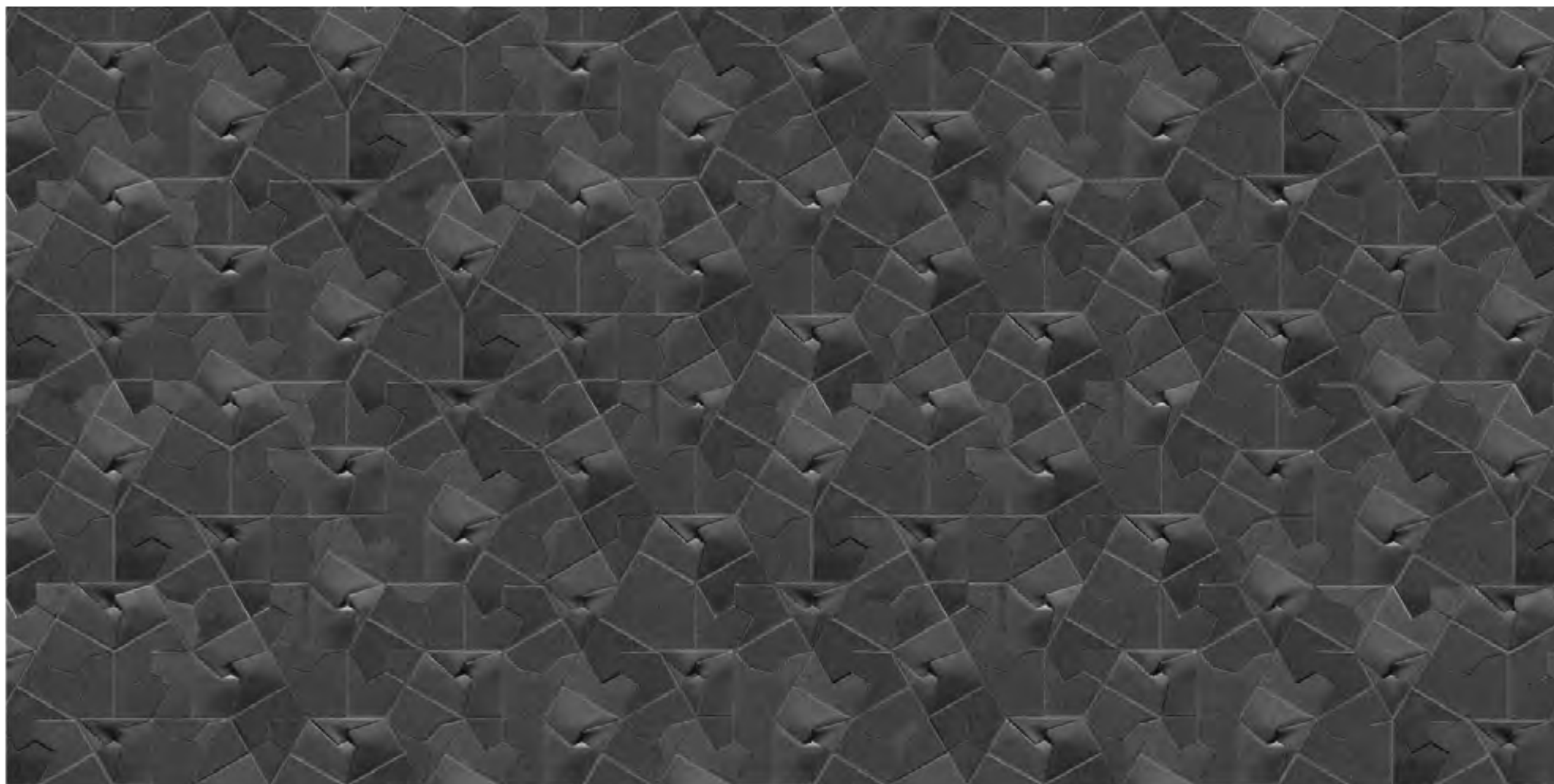

SIZE:  
4' 3/4 X 2' 3/8H  
124 X 62 CM

PATTERN #8



SIZE:  
36" X 48"H  
91 X 122 CM H

TITLE: "SPARKLING #1"  
1ST OF 15 PIECES  
ALL DIFFERENT EACH OTHER.

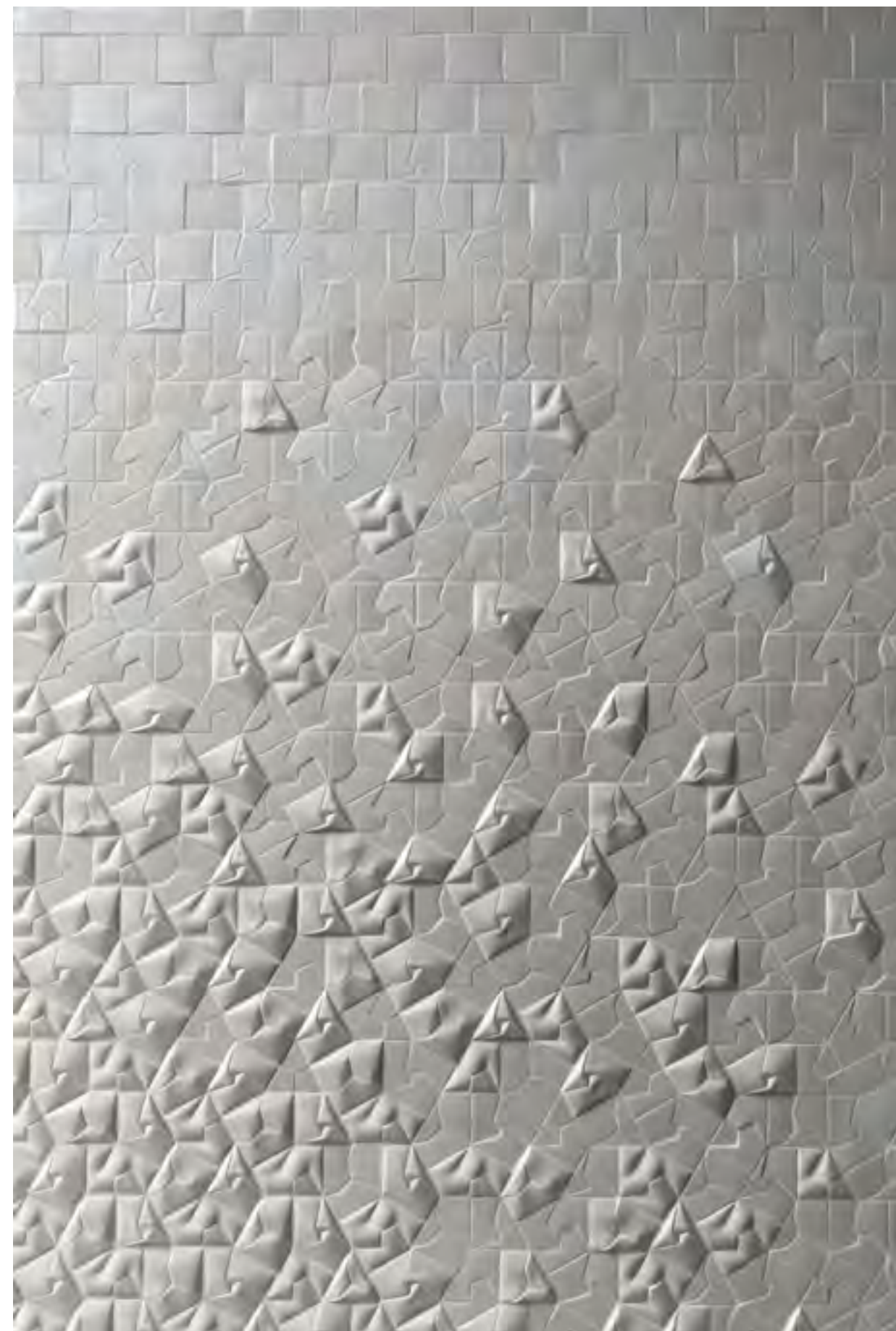



SIZE:  
36" X 48"H  
91 X 122 CM H

TITLE: "SPARKLING #2"  
2ND OF 15 PIECES  
ALL DIFFERENT EACH OTHER.





SIZE:  
55" X 12"H  
CM 140 X 30,5 H

CUSTOM MADE



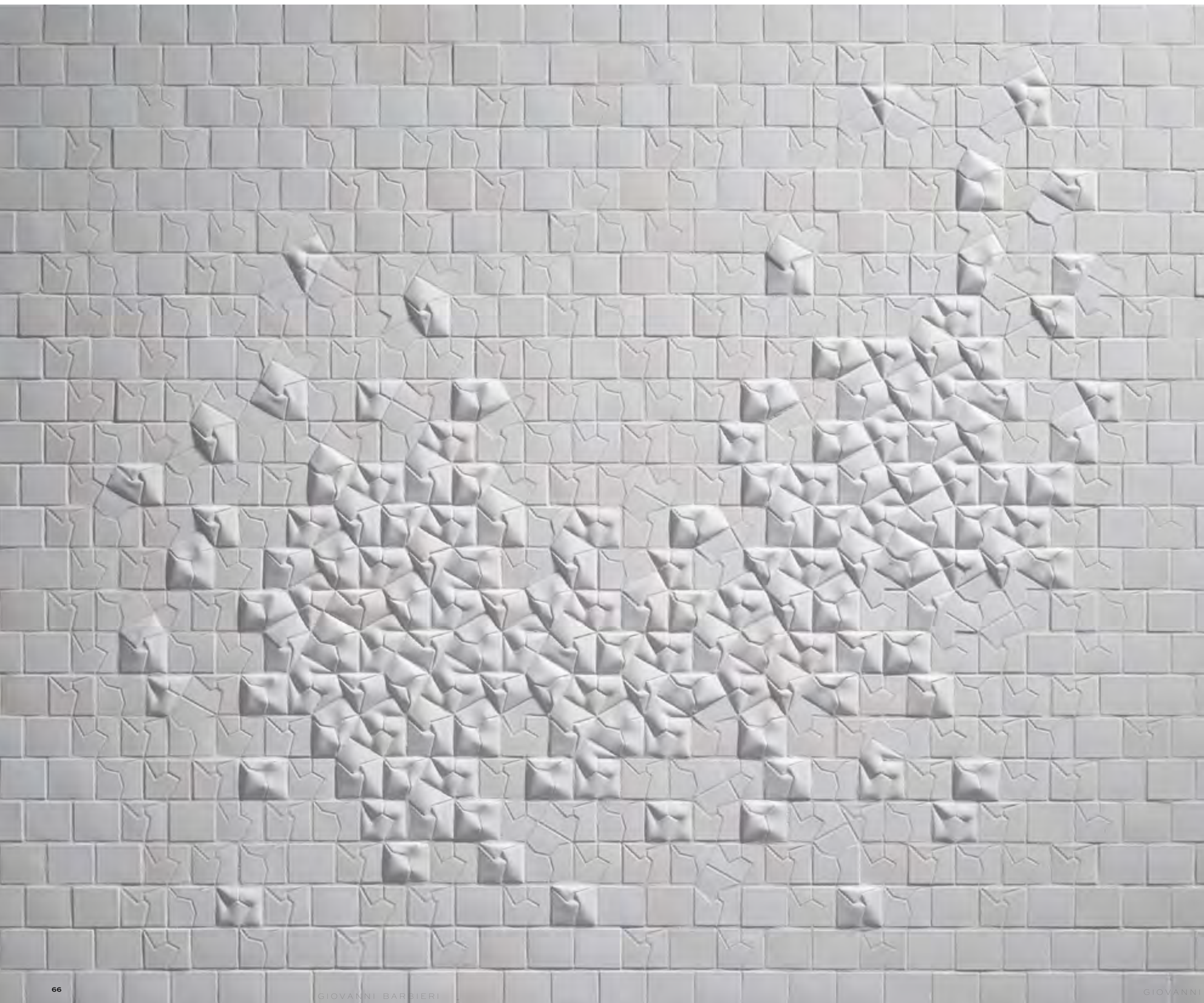

TITLE: "NUCLEUS" #2  
2ND OF 4 PANEL SERIES  
PANEL SIZE  
60" X 50"  
154 X 126 CM

## CUSTOM-MADE DIFFERENT VERSIONS



CARRARA MARBLE  
SIZE 4" X 5" (10 X 12 CM)

INFINITE TRANSITIONS AND COMBINATIONS CAN BE ACHIEVED, BASED ON THE AMBIENT LIGHTING AND YOUR TASTE, MAKING EACH PROJECT UNIQUE.

AVAILABLE FOR WALLS IN:

NATURAL STONE  
IN FLAT VERSION ONLY,  
SUITABLE FOR WALL AND FLOOR, IN HIGH HONED BRUSHED FINISH.

SIZE 4" X 5" (CM 10 X 12)  
IS PRODUCED EXCLUSIVELY BY  
ARTO.COM IN CALIFORNIA  
IN DIFFERENT VERSIONS

THE SQUAR COLLECTION OFFERS AN UNPARALLELED LEVEL  
OF PERSONALIZATION



reddot winner 2023  
best of the best



reddot winner 2023  
materials and surfaces design

# BLOOMING

“My first wooden floor.”

## “BLOOMING”

designed by Giovanni Barbieri,  
in cooperation with Flooma Parquet,  
received the Red Dot Product Design  
Best of the Best Award  
for its groundbreaking design and  
is the highest award in the competition.

An Artful Combination to behold.

In conjunction with the walls, the ceiling, furniture and lighting, flooring has a significant influence on the general appearance of a room, not least because of its surface area. Wooden floors create a natural, warm ambience, make the ground look inviting to walk on and are furthermore extremely resilient and durable. This is what may have prompted Italian stone and tile designer Giovanni Barbieri to create wooden flooring for the first time in his creative life. He succeeds in making an innovative concept come to life with his Blooming parquet flooring system, thus winning over the jury. “The carefully designed pattern, which changes with every bloom that is applied, creates an arresting impression and gives interiors a downright artistic atmosphere. The designer moreover manages to unite the benefits of prefabricated parquet flooring with the high-quality appearance of a custom-made product.”

Blooming combines sophisticated shapes that are never the same but always well-coordinated with the functionality of a simple, self-explanatory installation system. The multi-layered parquet consists of two bonded sheets of wood: a high-quality, durable oak layer sitting on top of a birch plywood substrate. To ensure its long-term durability, the parquet is glued and can also easily be installed with underfloor heating. Twelve different wood colours and four different surface finishes offer a wealth of design options to suit individual preferences. Depending on how the various colours of the oak are combined, it is possible to achieve either a striking, powerful rhythmic effect or – by selecting similar colours – a more uniform appearance. The eclectic floral pattern gives no indication that the parquet flooring system is ultimately based on only three standard shapes. Randomly installed, it hence produces a unique floor design for a lively room feel.

(Red Dot Award jury statement).

Design and technologies combined with extremely rare craftsmanship,  
have given birth to the new Blooming wooden flooring collection,  
generating a new sensation with the user  
that is not rational, it is wonderfully inexplicable.

In cooperation with Flooma Parquet.

[www.flooma.it](http://www.flooma.it)



## BLOOMING

Advanced parquet system  
by CNC routed oak flooring on birch plywood substrate.  
3 oaks pattern

**Starting 2024**  
we have been making advanced alternatives to this design available,  
much more versatile to satisfy less demanding budgets  
and above all extremely customizable:  
by confidential project service, only.



Blooming Collection is a CNC routed oak flooring on birch plywood substrate.  
With Blooming, the concept of varying the shape of each applied flower leads to a striking aesthetic.  
The resulting shapes have an extraordinary effect, especially on large surfaces,  
and create distinctive atmospheres in interiors.  
The perfectly thought-out design is also highly functional in terms of installation.



Their shapes changing appearance goes hand in hand with the functionality of a simple and self-explanatory installation system: together, it allows for aesthetic results in different shapes with a visually striking effect. This gives installed tiles the appearance of a custom finish design, the effect of which goes far beyond the fact that there are actually only very few standard patterns.

To ensure its long-term durability, the parquet is glued and can also easily be installed with underfloor heating.

All technical spec.s, special pieces for easy installation start and all setting instructions, are available upon project request.



LE PIASTRELLE  
SEGNATE

BY

fornace  
brioni

DESIGN BY  
GIOVANNI BARBIERI



2011 winner 2011  
Award of the Best



## LE PIASTRELLE SEGNATE

Terracotta tiles handmade in Italy.

With these wall and floor tiles, the concept of varying the density of the relief applied to them leads to a striking aesthetic. The resulting structures have a highly impressive effect, especially on large surfaces, and create distinctive atmospheres in interiors. The perfectly thought-through design is also highly functional in terms of installation and allows seamless adaptation to individual preferences.

(Red Dot Award jury statement).



SABBIA



CENERE



TERRA



**reddot** winner 2022  
best of the best

“Le Piastrelle Segnate”  
designed by Giovanni Barbieri for Fornace Brioni,  
received the Red Dot Product Design  
Best of the Best Award  
for its groundbreaking design and  
is the highest award in the competition.

Style-defining structure.

Tiles have always had a special significance in architecture, and their design usually corresponds to the style of the respective epoch.

Le Piastrelle Segnate are wall and floor tiles that impart a distinctive presence through their relief structure of three-dimensional appearance.

The concept comprises three types of tiles measuring 20 x 20 cm, each distinguished by the density of the reliefs applied to it.

Their changing appearance goes hand in hand with the functionality of a simple and self-explanatory installation system.

Together, this makes it possible to achieve aesthetic results that are doubly unique, with an impressive effect of high visual impact.

On the one hand, the conjunction of different reliefs in the three models available creates structures of different lengths, resulting in fascinating plays of light and shadow.

This lends the installed tiles the appearance of a customised finish design, which in its effect goes far beyond the fact that there are actually only three standard models.

On the other hand, the shading of the three models, from very dense relief structures to field tiles, as well as the use of accessory elements, make it possible to realise a wide variety of decorative solutions.

(Red Dot Award jury statement).



**2023**  
**Luxe USA Magazine RED Award Best Tile Design**  
“Le Piastrelle Segnate” for Fornace Brioni - Clè Tile USA  
RED ( Residential Excellence in Design )  
Award Winner as 2023 Best Tile Design



Lubjiana - Slovenia - 2022

**WINNER**  
Product Design Award  
HOME Category



New York City - 2022

**HONOREE AWARD**  
Wall Coverings: Tile & Stone  
category



COLORS & DIMENSIONS



CM 20 - 8"

CM 20 8"



MM 18 3/4

MM 25 1"



## INSTALLATION LAY-OUT

QUICK RANDOM INSTALLATION OBTAINING  
ALMOST NEVER REPETITIVE AND UNIQUE LOOK.

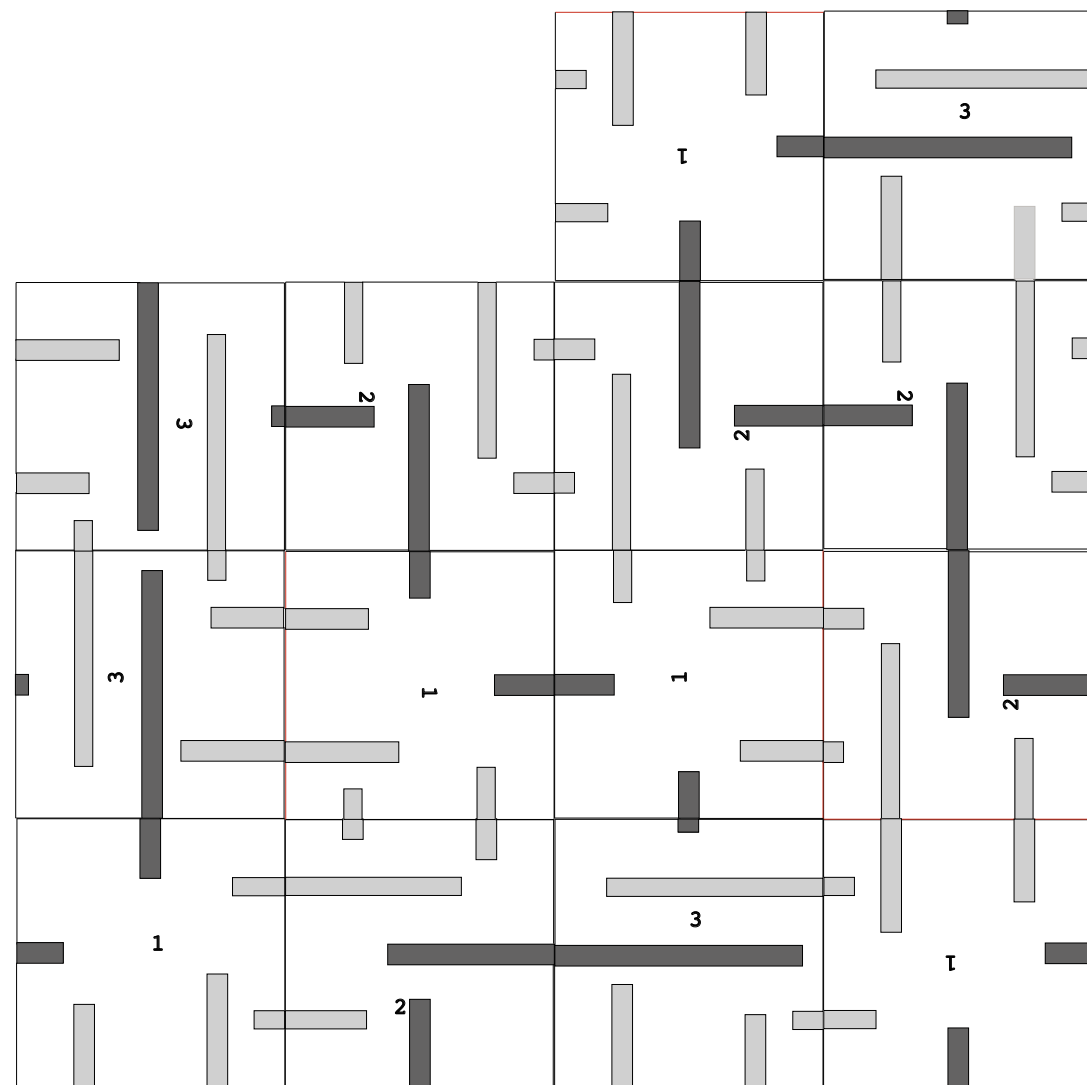

JUST SIMPLY TAKING CARE TO MATCH  
DOUBLE AND SINGLE SIGNS TILE SIDES EACH OTHER.

THE LAYING OF THE FIRST OR UPPER ROW  
MUST BE STARTED ONLY ON ONE SIDE OR IN THE MIDDLE  
NEVER FROM TWO DIFFERENT POSITIONS  
AT THE SAME TIME ON THE SAME

## 3 MODELS

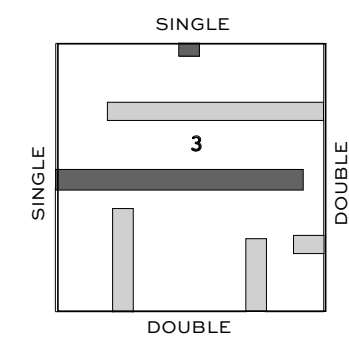
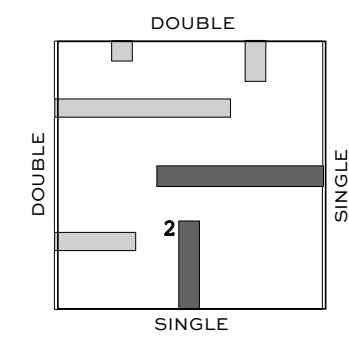
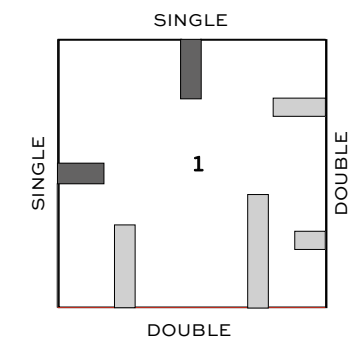



“ A contemporary hieroglyphic “  
Giovanni Barbieri.



“The decorative tiles becomes the part in movement of an empty, static wall “





“A wall covering must always appear to be in constant motion, never static or repetitive, because it represents the times we are living in.”

GIOVANNI BARBIERI





London UK Event at  
Nobu Hotel Portman Square  
22nd October 2021

REGOLI Collection  
has been selected as finalists at SBID  
(The Society of British International Interior Design)  
London International Design Awards.



New York City City Event at  
Cipriani South  
21st September 2021

REGOLI Collection  
has been selected as finalists  
at Hospitality Design Awards

## REGOLI

### “A STATEMENT OF SOPHISTICATED SIMPLICITY ABOUT HERRINGBONE PATTERN”

A long profound perseverant reasoning, as I normally apply to each of my creations, determined the discovery of a intelligently combine different lengths of listellos, also adding a play of inserts that help easy installation, obtaining a unique aesthetic final result, at the same time. Regoli Collection, in this new way of playing with the listellos, it allows you to create always different patterns simply by positioning randomly the three models respecting only the connection of the inserts, or following the desired direction of the herringbone pattern at the same time; moreover, the play of the rough connected inserts always creates lines of different lengths allowing to obtain a different aesthetic result in each installation, normally achievable only with careful planning and custom manufacturing.

With Regoli you bring into your project a new contemporary creation by Giovanni Barbieri, which at first sight recalls the shapes of the concrete structures by Carlo Scarpa used in his Treviso project/ creations.

The Regoli collection is made in Italy  
on Bianco Carrara  
12 “x 12” x 3/8 marble tiles  
with the artisan technique of “Acquaforte”,  
creating detailed textures engraved on  
polished natural stone surface.



LINEAR MODELS

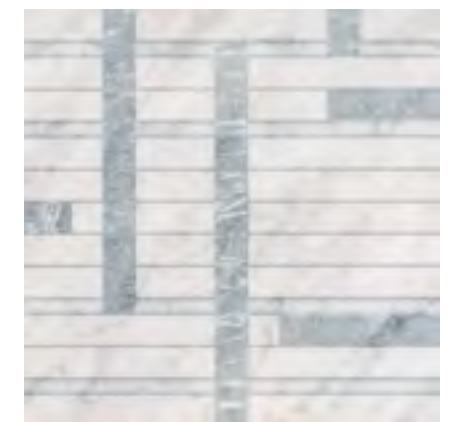

CM 30,5 / 12"

CM 30,5 / 12"

HERRINGBONE MODELS



CM 30,5 / 12"

CM 30,5 / 12"



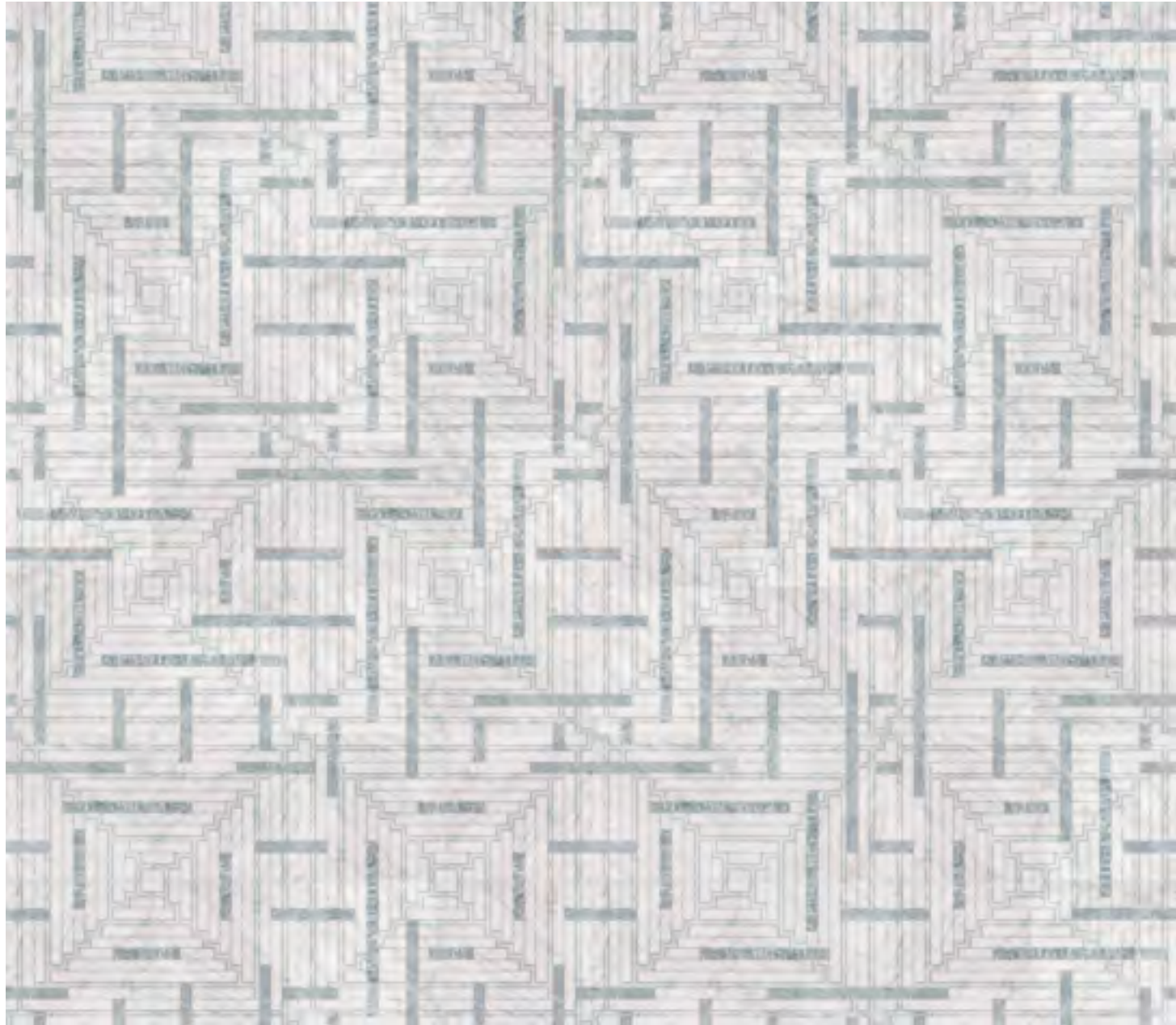

HERRINGBONE MODELS ONLY

HERRINGBONE MODELS ONLY



HERRINGBONE + LINEAR MODELS



HERRINGBONE + LINEAR MODELS



CONTEMPORAINE



“UN LUSO SENZA PRETESE“  
 (“AN UNPRETENTIOUS LUXURY“).

# CONTEMPORAINE



CARRARA MARBLE, 1" 1/2 x 1" 1/2 - 3,7 X 3,7 CM

THE EVOLUTION OF OUR EXCLUSIVE PRODUCTION PROCESS,  
AND THE EXTREME DESIRE TO MOVE TO A HIGHER LEVEL  
OF QUALITY OF MY CREATIONS,

ALLOW US NOW TO PRODUCE A NEW VERSION OF MOSAIC,  
WITH A CONTEMPORARY LOOK,  
APPARENTLY RIGOROUSLY REFINED IN FINISH  
AND HOMOGENEOUS IN SHAPES.

BY CAREFULLY OBSERVING THEIR DETAILS,  
YOU WILL BE SURPRISED BY THE SOPHISTICATION,  
BARELY PERCEPTIBLE DIFFERENCE OF EACH PIECE  
AND EVERY SINGLE SURFACE,  
OBTAINING A NEW AESTHETIC  
THAT IS EVEN MORE PERCEPTIBLE TO THE TOUCH AND  
FROM ITS EVER-CHANGING PLAY OF HIGH HONED REFLECTIONS:  
MODERN, MINIMAL.

ALL RESUMING AS:  
**A TIMELESS SOPHISTICATED SIMPLICITY.**

AVAILABLE IN THE FORMAT  
1" 3/8 X 1" 3/8 (3.5 X 3.5 CM),  
BOTH STRAIGHT AND STAGGERED,  
ON 1,0 SQ FT NET ( 30,5 X 30,5 CM )  
IN CARRARA MARBLE, ONLY.



“UNA SEMPLICITA’ SOFISTICATA”  
 (“A SOPHISTICATED SIMPLICITY”).



CARRARA MARBLE, 1" 1/2 x 1" 1/2 - 3,7 X 3,7 CM



PANEL SIZE 24" X 24" - 61 X 61 CM

# Depthile

CARRARA MARBLE TILE WITH STRAIGHT AND CUSCION EDGE IN HIGH HONED SURFACE.

THE RESULT OBTAINED IS MINIMALIST AT FIRST SIGHT AND SOPHISTICATED AT SAME TIME ONCE SEE AND TOUCH THEIR DETAILS.

THE UNIQUE SHADING EDGE EFFECT ENHANCED BY SIMPLY NATURAL OR ARTIFICIAL LIGHTING OBTAIN DEPTH LOOK, AND, IN THE SAME TIME, OFFERING EASY INSTALLATION AND CLEANING MAINTENANCE.

“DEPTHILE” IS THE FIRST NATURAL STONE TILE HAVING SOFT THREE-DIMENSIONAL EFFECT MANTAIN IT’S FLAT SURFACE WITH REAL UNIQUE LOOK, SUITABLE FOR FLOORS AND WALLS.

THE CUSCION EDGE HELP TO OBTAIN COMFORTABLE WALL COVERINGS TERMINALS FOR BATHROOM AND KITCHEN APPLICATIONS.

DESIGNED IN 2018.

“DEPTHILE COLLECTION”  
IS AVAILABLE IN THE FOLLOWING SIZES:

2” X 12” X 3/8 / CM 5 X 30,5 X 1

3” X 18” X 3/8 / CM 7,5 X 45,7 X 1



**DEPTHILE**

2" x 12" x 3/8 / Cm 5 x 30,5 x 1  
3" x 18" x 3/8 / Cm 7,5 x 45,7 x 1  
Carrara Marble Tiles



**DEPTHILE**

3" x 18" x 3/8" / 7,5 x 45,7 x 1 Cm  
Carrara Marble Tiles .





AURORA LODGE,  
(NORD LENANGEN) NORWAY  
BY SNORRE STINESSEN

2" x 12" x 3/8 / 5 x 30,5 x 1 Cm Carrara Marble Tiles  
Photo credit: August Stinessen - Melissa Hegge - Snorre Stinessen

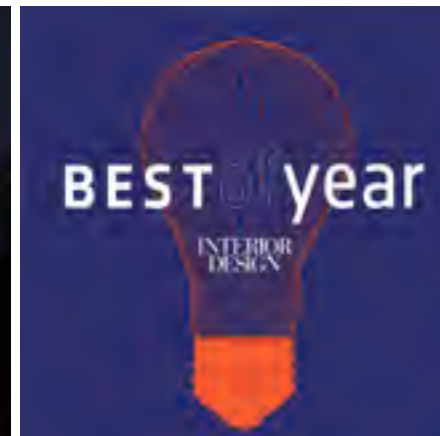

Depthile Carrara Marble tiles has been installed on INTERIOR DESIGN Best Of Year Award Winner project/Bath by Snorre Stinessen.

Aurora Lodge by Snorre Stinessen in Norway. has been Architizer A+Awards Award Winner on residential category.



2" x 12" x 3/8 / 5 x 30,5 x 1 Cm Carrara Marble Tiles



2" x 12" x 3/8 / 5 x 30,5 x 1 Cm Carrara Marble Tiles



2" x 12" x 3/8 / 5 x 30,5 x 1 Cm Carrara Marble Tiles





2" x 12" x 3/8 / 5 x 30,5 x 1 Cm Carrara Marble Tiles

**CUSTOM MADE DESIGN SERVICE**  
 when a customer sees one of our pieces of art  
 and decides to have an entire floor in the same way...

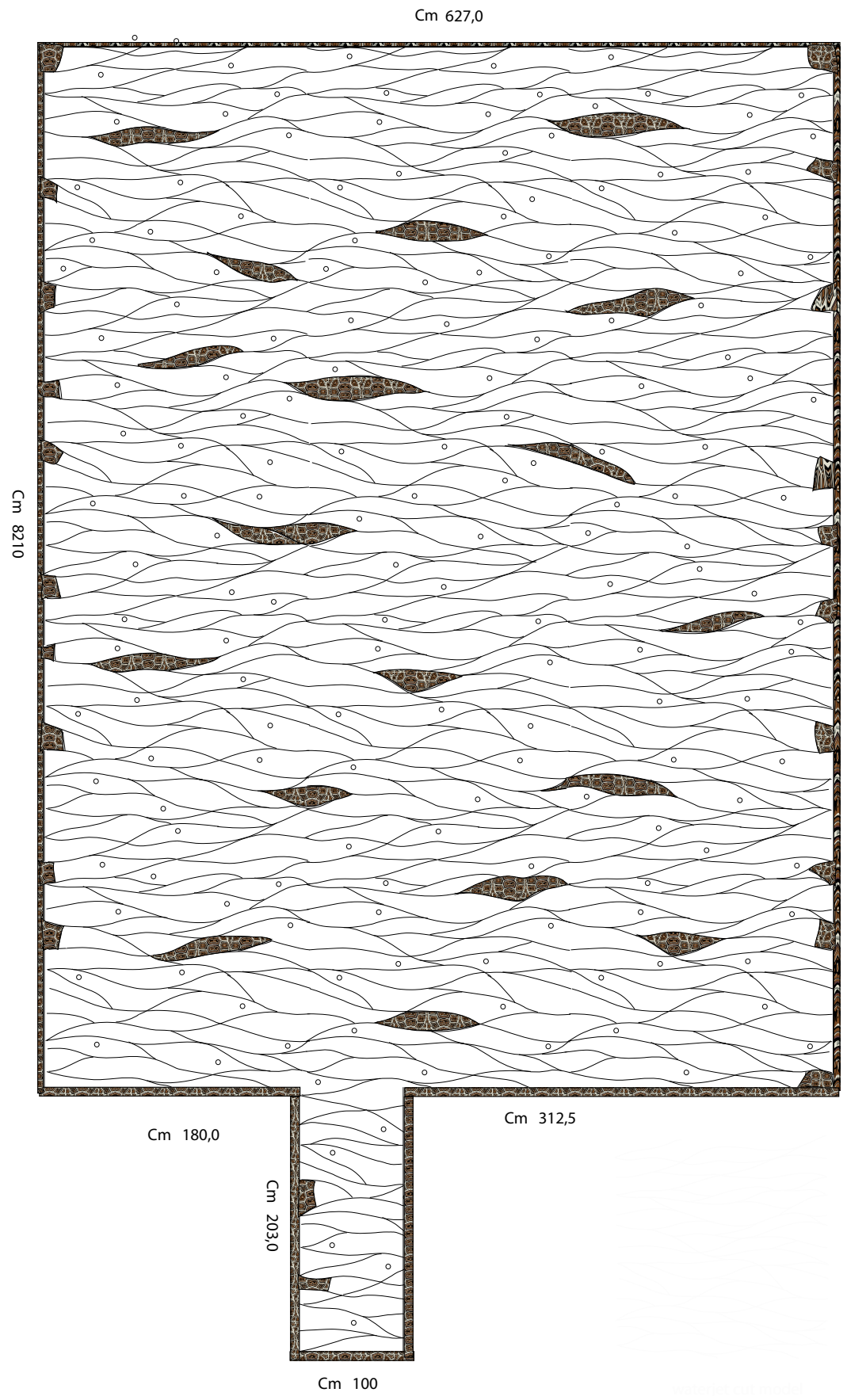

PANEL SIZE 24" X 24" - 61 X 61 CM (SEE AT PAGE 209)

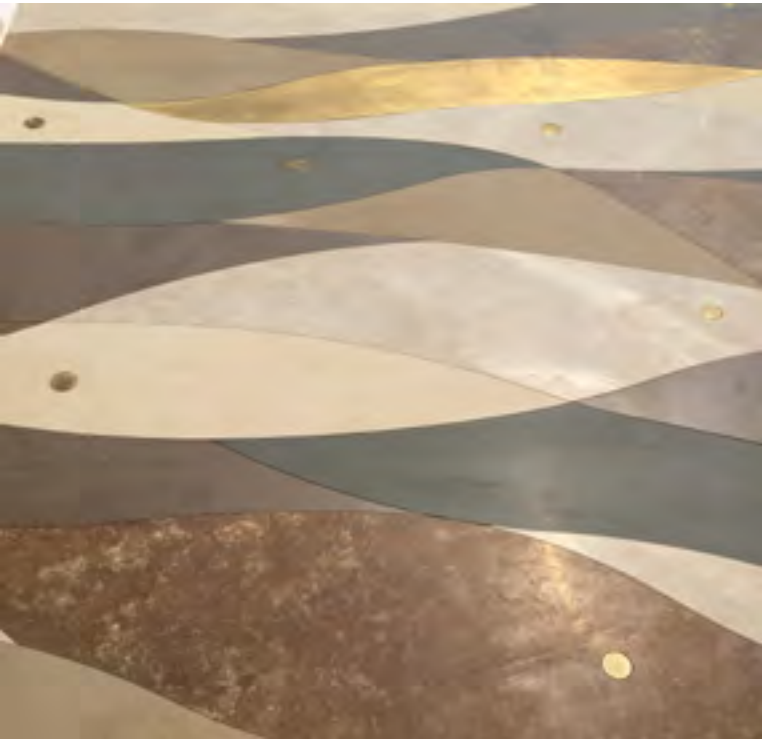

MOCK-UP BOARD DETAIL

UNEDITED DESIGNS

AND

RARE VENETIAN ARTISAN SKILLS...

...SET US APART

IN

TAILOR-MADE PROJECTS.

Personal meeting by appointment only, available at:

- Giovanni Barbieri studio and Lab.: Schiavon 36060 Vicenza

- Venice spring and fall monthly temporary showroom in Sestiere San Marco

- New York City showroom at Surfaces & Co. USA  
19 West 21st Street, Ste. 204 New York, NY 10010 Tel. 212-918-8101



## THE TIMEWORN MARBLE MOSAIC.

THIS NEW PATTERN ON UNIQUE SURFACE FINISHING  
IS OBTAINED THROUGH NEW TECHNOLOGY THAT IS AN EVOLUTION OF INVENTION  
BY GIOVANNI BARBIERI SINCE 1999.

THE PROCEDURE FIRST WEARS OUT THE BORDERS OF THE TILES  
THEN CREATES SEMI-OPAQUE NATURAL WAVY SURFACE;

THE PROCEDURE WHICH "CONSUMES" THE SOFTER PARTS OF THE MARBLE COMPOSITION  
AND ALSO ALLOWS THE SUBSEQUENT POLISHING APPLIED IN THE SAME GRADE OF AN  
ORIGINAL HISTORICAL FLOOR.

THE WHOLE PROCEDURE IS DONE WITH ECOLOGICAL ABRASIVE ONLY.

THE DEGREE OF SURFACE SHEEN IS THE SAME AS THE ORIGINAL SHEEN ON THE FLOORS OF  
THE HISTORICAL BUILDINGS IN OUR ITALIAN CITIES.  
NO MATTER THE AMOUNT OF USAGE AND TRAFFIC THAT THAT THE MARBLE IS SUBJECTED TO,  
ITS SHEEN AND ITS UNIQUE REFLECTIONS REMAIN UNALTERED.





## BIANCO ANTICO ITALIAN MARBLE

2" X 4" STAGGERED MESH MOUNTED

2" X 2" SQUARED MESH MOUNTED

THICKNESS 3/8 ON 1,0 SQ. FT. NET

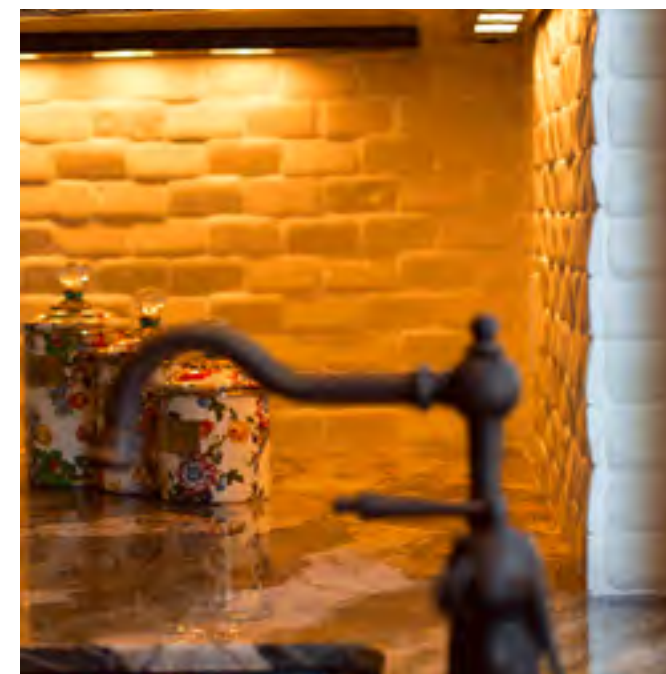



2" X 4" STAGGERED MESH MOUNTED  
 2" X 2" SQUARED MESH MOUNTED  
 THICKNESS 3/8 ON 1,0 SQ. FT. NET



CARRARA 2" X 4"

COURTESY OF: [WWW.COUNTRYFLOORS.COM](http://WWW.COUNTRYFLOORS.COM) USA

AND

[WWW.HOUSEOMETRY.COM](http://WWW.HOUSEOMETRY.COM) CALIFORNIA



CARRARA 2" x 2" x 3/8  
 ON 1,0 SF NET



BIANCO ANTICO 2" x 4" x 3/8  
 STAGGERED ON 1,0 SF NET

# THE HERRINGBONE

SIZE 1", 1" 1/2 AND 2" x 6" LENGTHS  
ON NET SIZE 0,33 SQ. FT, TOTAL THICKNESS 3/8 - 1/4  
2 MODELS CREATING TWO PATTERNS.  
CARRARA AND BIANCO ANTICO ITALIAN MARBLE.

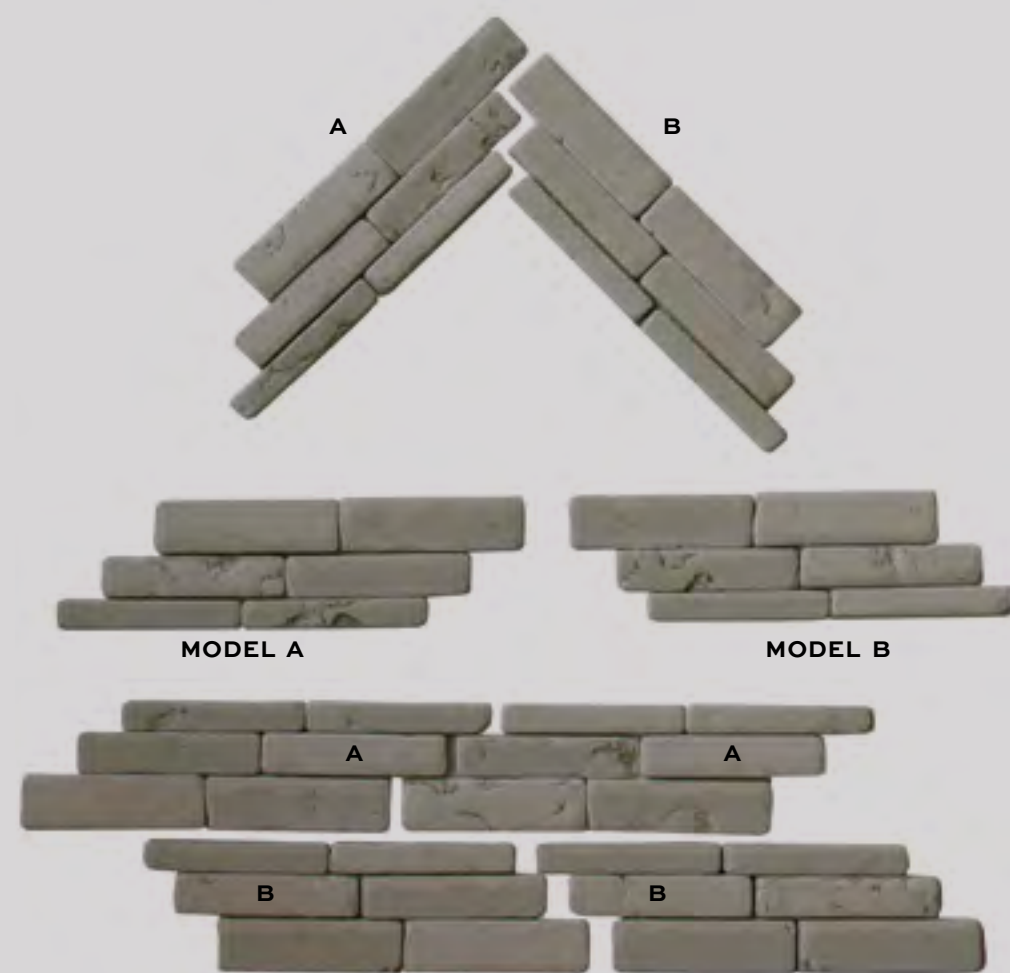

BIANCO ANTICO



THE HERRINGBONE



FREE LENGTHS LOOK

## THE FLAT VERSION TIMEWORN MOSAICS

The New Timeworn FLAT version Mosaic having less structured textures than before, much more harmoniously consumption high honed surface finishing, suitable and comfortable for floor with new patterns also, giving a much more sophisticate and genuine look.

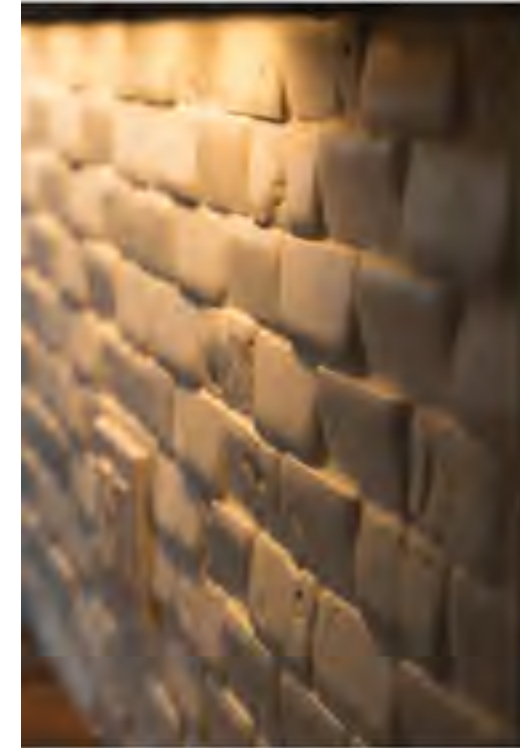

Original version

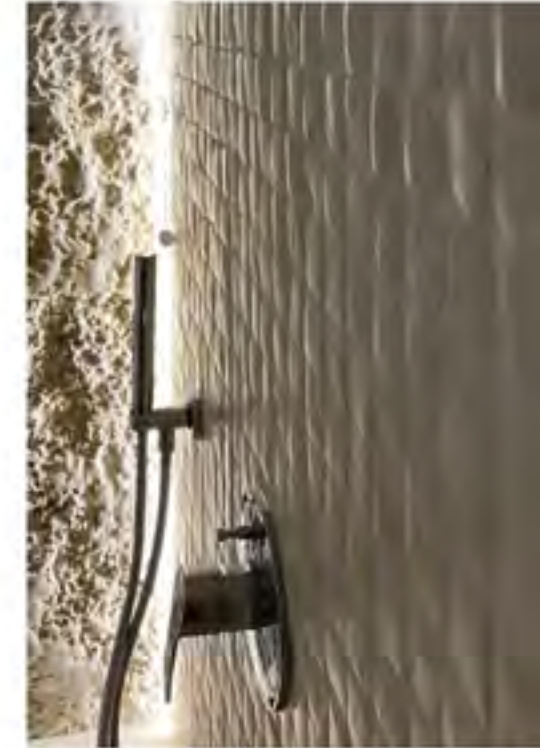

New version





3/8 X 4" X 3/8 X 3/8 (1X10X1CM) ON 1,0 SQ. FT. NET.



BIANCO ANTICO MARBLE 1/2 X 4" X 3/8 ON 1,0 SQ. FT. NET.



BIANCO ANTICO HEXAGON 1" 3/8 (3,5 CM) SIDE ON 0,9 SQ.FT. NET



CARRARA MARBLE



BIANCO ANTICO 2" X HANDCUT SHORT FREE LENGTHS X 3/8 ON 0,93 SQ. FT. NET.



SPECIAL MOSAIC SHEET THAT ALLOWS SHADING FROM 2" X 2" TO 2" X HAND CUT.



CARRARA 3" (7,5 CM) X SHORT FREE LENGTHS, X 3/8 ON 0,97 SQ. FT. NET.





BIANCO ANTICO



CALACATTA



CARRARA



CARRARA MARBLE, PATTERN #33 ON NET 16" X 16" (40,6 X 40,6 CM)

CUSTOM MADE

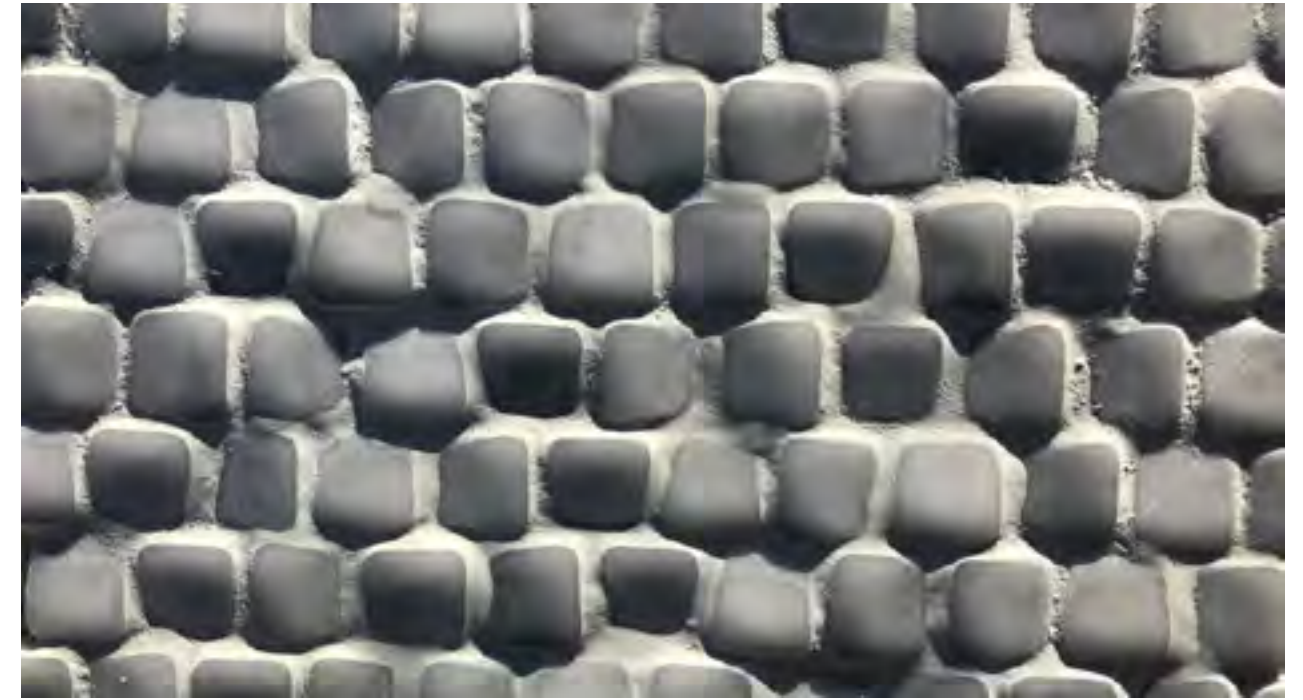

1" X 1" X 3/8 (2,5 X 2,5 X 1) STAGGERED ON 0,93 SQ. FT. NET.



3/8 X 3" X 3/8 (1 X 7,5 X 1 CM) ON 1,72 SQ. FT. NET (16" X 16" X 3/8 / 40,6 X 40,6 X 1 CM)



1" 3/8 X 1" 3/8 X 3/8 (3,7 X 3,7 X 1 CM)

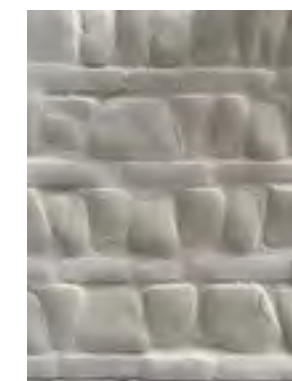

PATTERN #13  
2" X HANDCUT  
+  
3/4 X 2" - 3"



3" + 2" X HANDCUT  
7,5 + 5 CM HAND CUT



Overall Winner at International SBID (The Society of British International Interior Design) London Design Awards 2020.

The Fine Lines by Barbieri

“Selected from the Flooring & Floorcoverings category, The Fine Lines strikes the balance between crafting a handmade, artisan tile collection and achieving premium art performance.”



New York City Boutique Design

International Product Design competition.

“The Fine Lines Terrazzo by Barbieri has been selected as a WINNER in the Hard Surface Flooring category for the 2020 BD Product Design Competition.

Presented by Boutique Design magazine and BDNY, the competition celebrates designers and manufacturers of products that demonstrate aesthetic progress, functionality, and above all, innovation”.



New York City City Event at Cipriani South  
21st September 2021

The Fine Lines Terrazzo Collection has been the Winner at Hospitality Design Awards #HDAwards 2021 on flooring category.

# THE FINE LINES

ITALIAN TERRAZZO  
CUSTOM MADE TILE



Handmade  
Terrazzo decor 38"x38"  
(97x97 cm).  
Made by  
Giovanni Barbieri  
begin of the 90's

# THE ITALIAN TERRAZZO CUSTOM MADE

## THE FINE LINES COLLECTION

Born from the union of  
the knowledge of the  
Terrazzo technique &  
design by Laboratorio  
Morsetto in Vicenza  
and Giovanni Barbieri.



## THE FINE LINES

This pattern has been created by Giovanni based on simple but important characteristic: creating an easy-to-install, intricate, and unique, non-repetitive aesthetic result at the same time.

“The Fine Lines Collection”  
dimensions of each model:  
23” 5/8 x 23” 5/8 x 3/4  
( 60,0 x 60,0 x 2 cm )  
The 3 models/patterns  
all together are 11,61 SF  
( 1,08 SqM ).

Available in custom made colorways using Natural Stone, including metal or terracotta on decorative inlays, also.

The surface finish is standardly High Honed and could be Polished or Timeworn upon request.



**STANDARD TERRAZZO  
COLOURWAYS  
AND GRANULOMETRY**

**PALLADIANA  
MARBLE COLOUR  
INLAYS**



**BERGAMO 12**

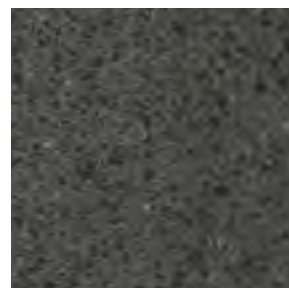

**TRENTO 12**

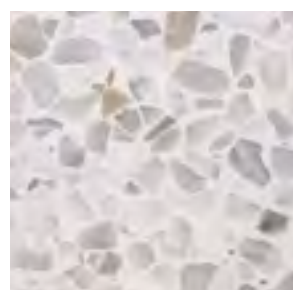

**MANTOVA 12**



**BRESCIA 12**



**BOLOGNA 12**

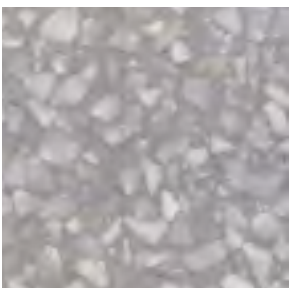

**ISEO 12**

**GRANULOMETRY  
SIZES**

12 = 1/5" (12 mm)

OTHER COLORS ARE AVAILABLE UPON  
SPECIAL REQUEST.

**STANDARD COLOUR**

- CARRARA
- CALACATTA
- BARDIGLIO IMPERIALE
- BIANCO ANTICO MARBLE
- BLACK LIMESTONE
- LIGHT GREY TERRACOTTA
- BLACK TERRACOTTA
- LIGHT BEIGE TERRACOTTA

OTHER COLORS ARE AVAILABLE UPON SPECIAL REQUEST.

DETAILED COLOUR PICTURE ARE SUPPLIED IN REFERENCE OF EACH SINGLE ONE NATURAL  
SHADES AVAILABILITY.

SAMPLE FOR FINAL APPROVAL IS SUPPLIED BEFORE ORDER PRODUCTION STARTS.

### 3 PATTERN DECORATIVE MODELS

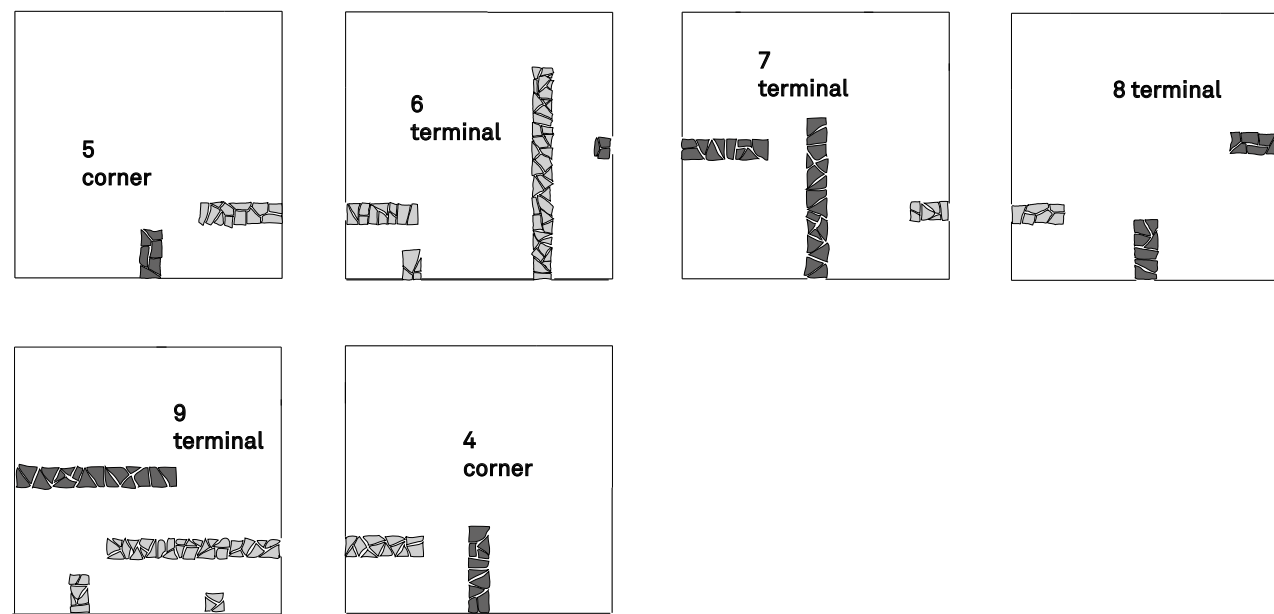
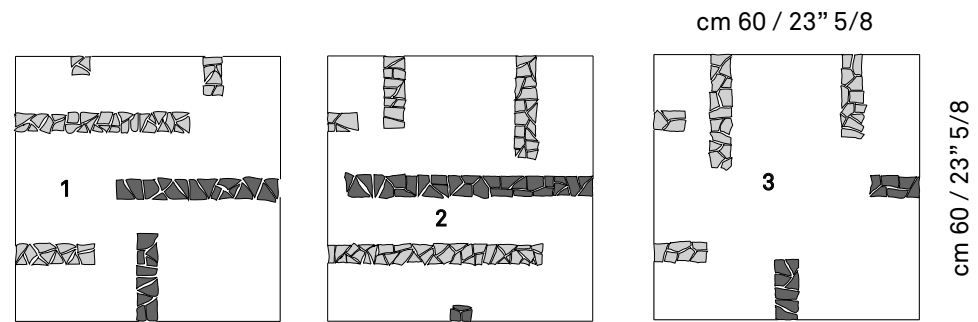

Decorative terminals / corners

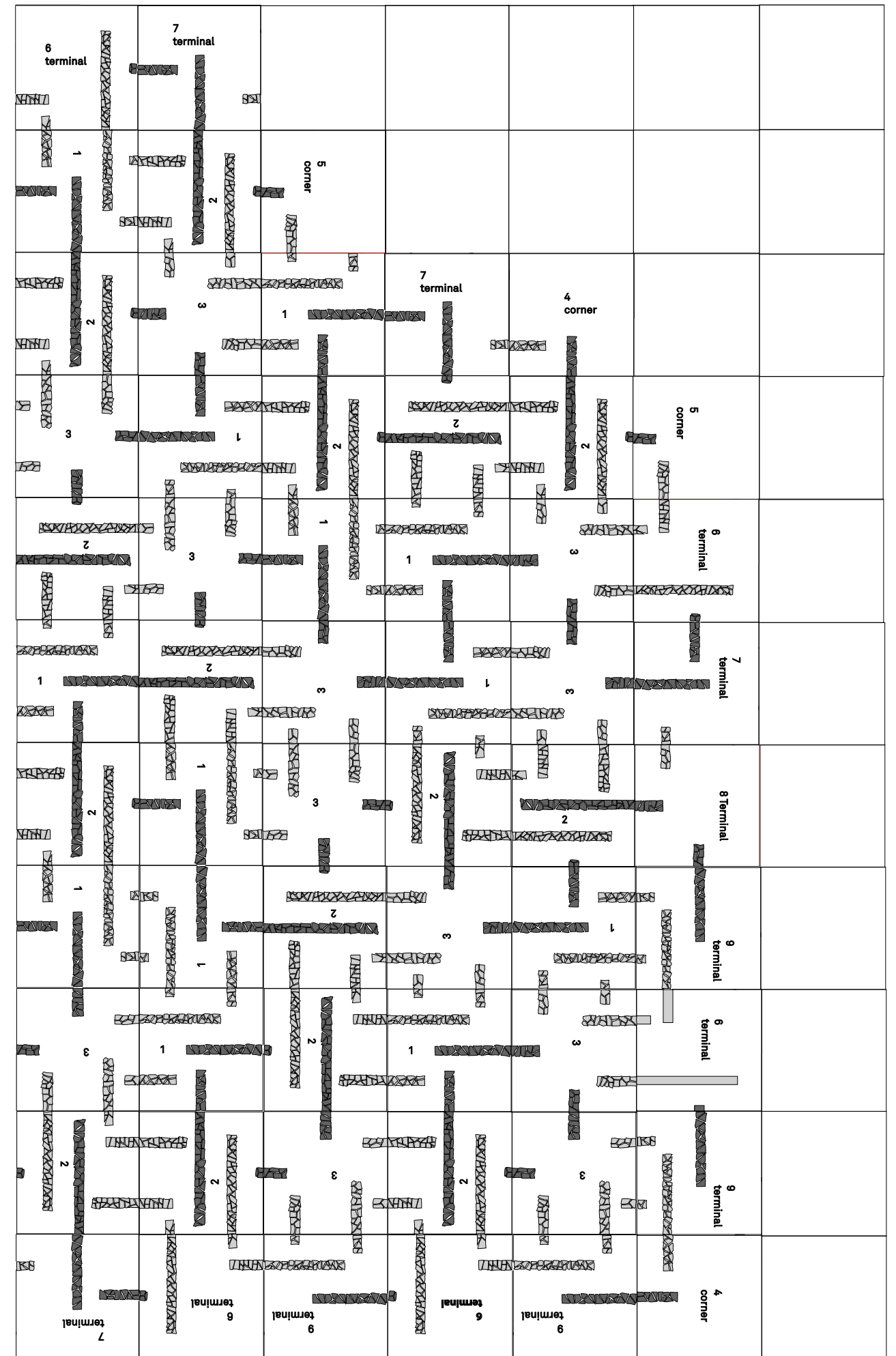



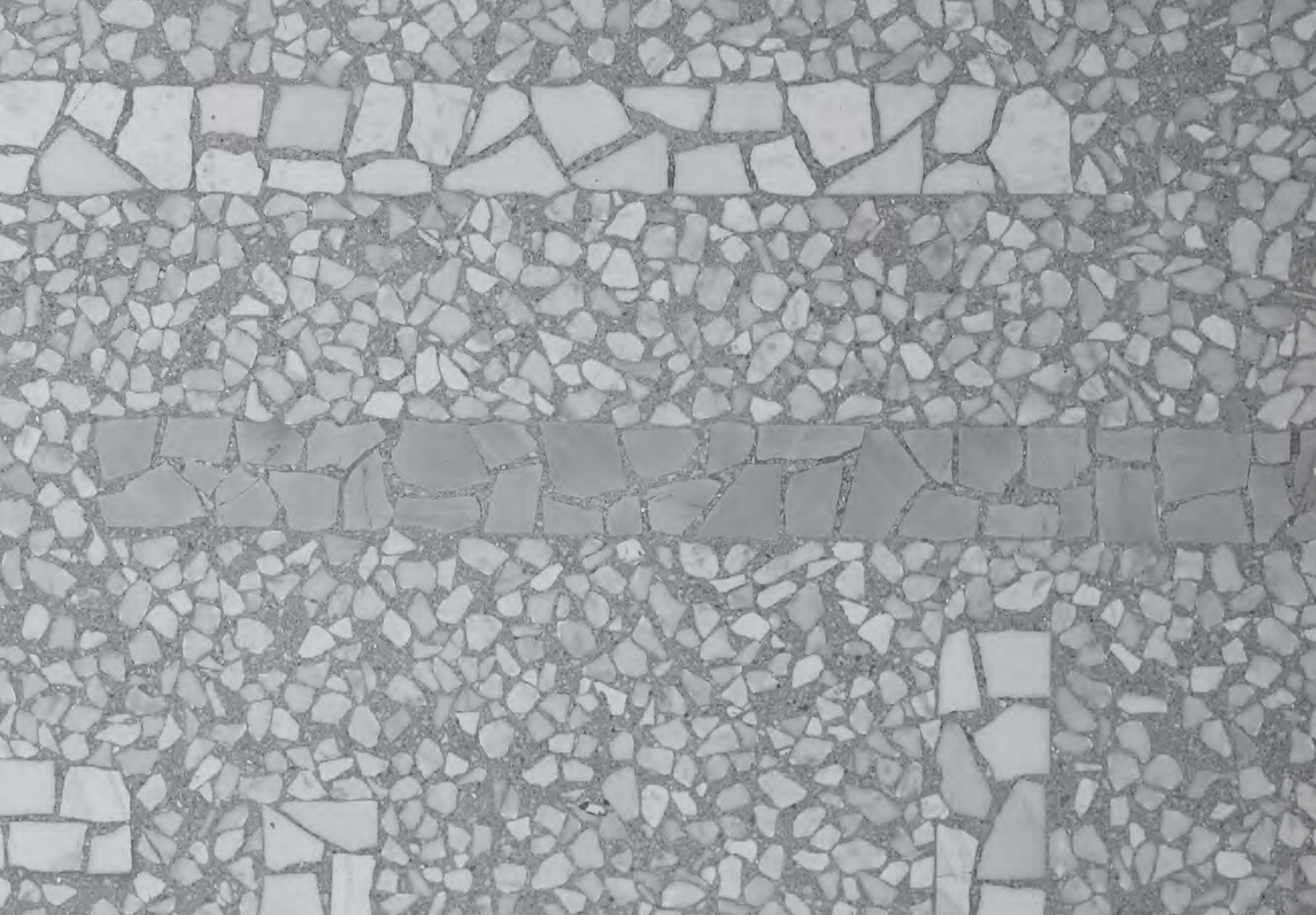

## MINIMAL RUSTIC

### Handmade Timeworn Terracotta

PROUD TO INTRODUCE LATEST ADVANGARDE RESULT OF  
ANTIQUED HANDMADE TERRACOTTA.

THE RESULT IS A UNCOMPARABLE COMBINATION OF  
TIMEWORN, IRREGULAR WAVY SURFACE FINISHING TEXTURE,  
AND SPECTACULAR BLACK COLOUR SHADES ON DARK WHITE DUST NUANCE.

IT HAVE HONED-POLISHED SURFACE EACH SINGLE TILE IN DIFFERENT PERCENTAGE  
THAT FOLLOW THE DENSITY OF THE SURFACE AND BODY STRUCTURE;  
THIS DETERMINATE FINALLY THE FIRST BLACK COLOUR TILES COLLECTION  
OFFERING EASY CLEANING AND MAINTENANCE SURFACE.

DUE TO ITS TIMEWORN SURFACE AND OLD LOOK,  
SIZES DEVELOPED ARE SUITABLE FINALLY ON

MINIMALIST INTERIOR DESIGN STYLE CONCEPTS  
WHICH GIOVANNI BARBIERI STRONGLY BELIEVE THE MARKET NEED.

AVAILABE IN DIFFERENT NUANCES AND SIZES ALSO.

WE SUPPLY PRESEALED FOR HELP EASY INSTALLATION AND GROUTING.  
FINAL SEALER APPLICATION IS SUGGESTED AT INSTALLATION TOTALLY COMPLETED.

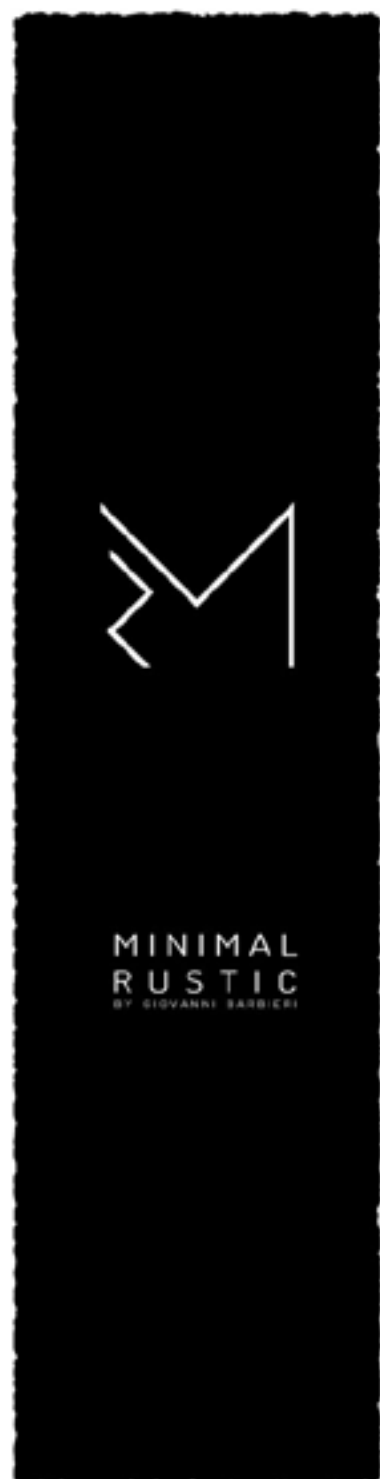

Inspired by the owl's house in London  
by Eddy Francois:  
an architect with a soul of a poet  
passed away too young.

This is a new alternatives:  
this match a request of antiqued black  
color floor that could be easily cleaned and  
still keep its striking, characteristic look.

This is why I developed

Minimal Rustic

a tile with a unique surface finishing, preserving the  
beauty of the black natural material and making  
the cleaning a breeze.

The black terracotta is made in Italy,  
by Fornace Brioni  
and finished at  
Barbieri Lab.



Squar Mosaic 4" x 5" ( 10 x 12 cm )

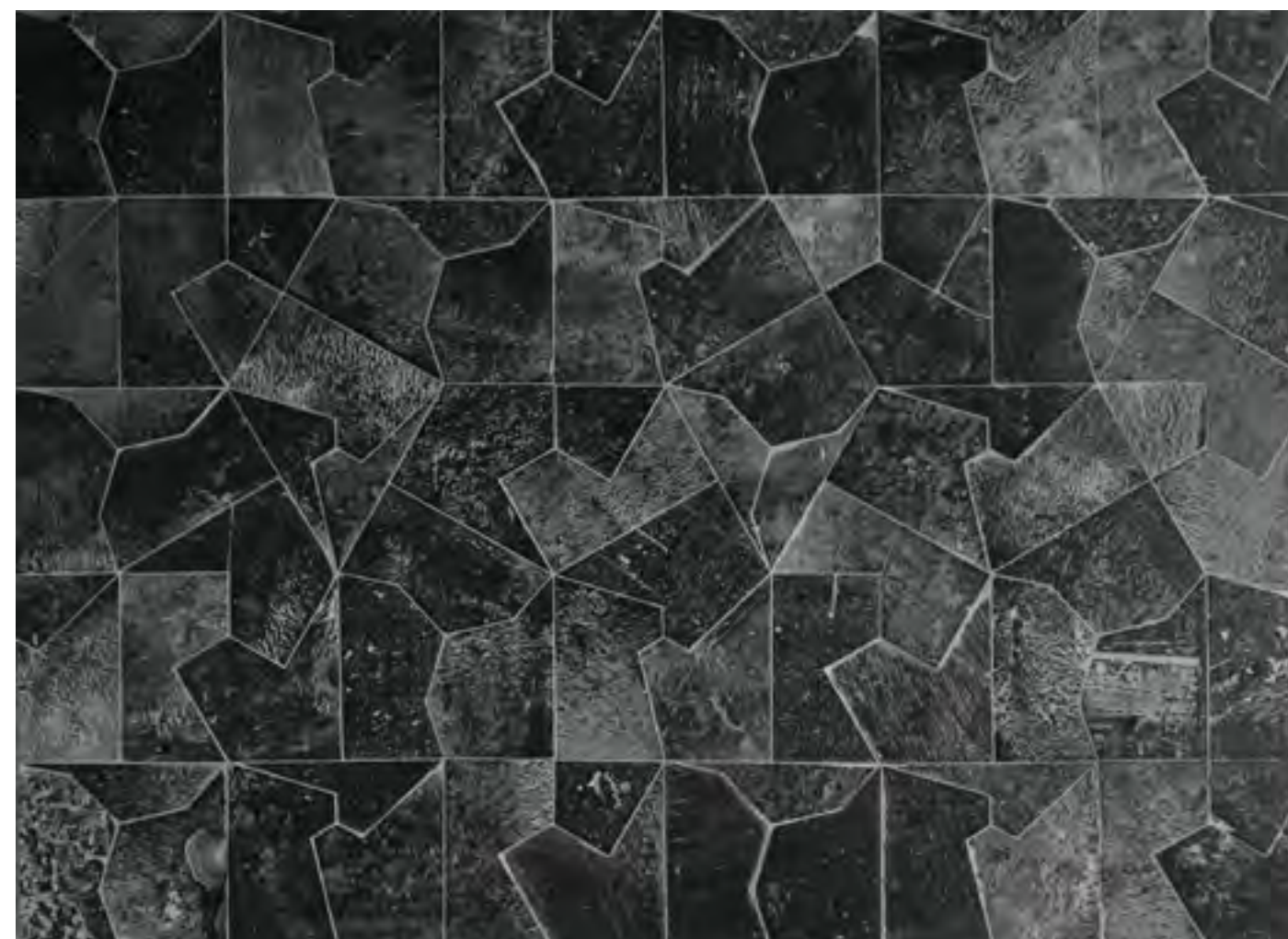



Tile size 7" x 15" x 1" (17 x 45 x 2,5 cm)



Tile size 7" x 15" x 1" (17 x 45 x 2,5 cm)



# THE MURANO COLLECTION

# THE MURANO COLLECTION

BREATHE NEW LIFE INTO HISTORICAL ITALIAN MATERIALS SUCH AS :

UMBRIA / TUSCANY/ VENETIAN HAND-MADE TERRACOTTA  
AND  
VENICE/MURANO GLASS  
THAT COMBINED WITH NATURAL STONES  
ORIGINATE A STUNNING NEW GENERATION OF DECORATIVE SLABS  
FEATURING A UNIQUE DUAL AESTHETIC RESULT:

A THREE-DIMENSIONAL SURFACE WITH GRAZING LIGHT  
OF MURANO GLASS IN RELIEF, THAT REMAINS  
MONOCHROM IF NOT BACKSIDE - ILLUMINATED,  
CREATING A HARMONIOUS PLAY OF CURVED SURFACES.

THE BACKLIGHTING OF THE SLABS RAISES THE VALUE OF COLOUR EFFECTS AND  
TEXTURES ATTAINABLE WITH THE HAND-MADE MURANO GLASS, ONLY.

THE MURANO COLLECTION OFFERS AN UTTERLY  
UNIQUE AESTHETIC, AVAILABLE IN INFINITIVE  
VARIETY OF COLOURS, PATTERNS AND DIMENSIONS.

The Murano Glass IS GLASS MADE ON THE VENETIAN ISLAND OF MURANO WHICH HAS SPECIALIZED IN FANCY GLASSWARE FOR CENTURIES. MURANO'S GLASSMAKERS LED EUROPE FOR CENTURIES, DEVELOPING OR REFINING MANY TECHNOLOGIES. VENETIAN GLASS IS WORLD-RENOWNED FOR BEING COLOURFUL, ELABORATE AND SKILFULLY MADE. TODAY, THE ARTISANS LIVING AND WORKING IN VENETIAN AREA ARE STILL EMPLOYING OLD TECHNIQUES AND ARE ABLE TO PRODUCE SLABS OF 30CM X 60CM AND OF 1 CM THICKNESS THAT THE BARBIERI ARTISANS CRAFT AND CUT OUT BY WATERJET FOR THEIR OWN PERFORMANCES. THE PRECIOUS ABILITY OF THE BARBIERI CRAFTSMANSHIP GIVES THE POSSIBILITY OF HAVING ANY GLASS COLOUR ON DEMAND.

AT THE SAME TIME ONE MUST NOTE THAT FOR EACH FUSION THE COLOUR SHADES MIGHT VARY AND ARE NEVER THE SAME UNAVOIDABLE FACTORS WHICH REPRESENT THE ORIGINALITY AND ARTISTIC CRAFTSMANSHIP.

The hand-made Terracotta IS ACHIEVED BY USING DIFFERENT APPROPRIATE REFINED CLAY SOILS WHOSE CHARACTERISTICS ARE ONLY PRESENT IN THE REGIONS OF CENTRAL AND NORTHERN ITALY. THANKS TO THE TRADITION AND TO THE SECRETS OF SEVERAL GENERATIONS OF ITALIAN CRAFTSMEN THAT MAKES IT POSSIBLE TO PROVIDE, IN ITALY ONLY, THE BEAUTIFUL COLOURS WHICH VARIES CONSIDERABLY AND ARE USED FOR THIS COLLECTION:

- LIGHT GRAY, BLACK, CHOCOLATE, KHAKI, LIGHT BEIGE AND THE RED ONE RECYCLED FROM THE DEMOLITION/RENOVATION OF OLD HOUSES  
THE HAND-MADE TERRACOTTA, A TYPE OF EARTHENWARE THAT IS AVAILABLE IN NATURE, IS FORMED TO THE DESIRED SHAPE BY PLACING THE CLAY-BASED BODY INTO A WOOD TILE AND LET IT DRY NATURALLY.  
ONCE THE TILES BECOME EASY TO HANDLE THEY ARE PLACED IN A KILN AND THEN FIRED WITH PRODUCTION CYCLE OF ABOUT 10 DAYS; THIS PROCEDURE IS NEEDED TO AVOID BREAKAGE OF THE TILES.  
THEY ARE THEN CUT INTO THICKNESS AND CUT OUT BY HAND OR BY WATERJET PROCEDURE.

The Barbieri Family Artisans, SINCE 1975 IS AN ETERNAL QUEST FOR PERFECTION IN AMUSING WAY WITH MARBLE.  
THE QUALITY OF THEIR HAND-MADE WORK COMBINED WITH THE QUALITY OF GIOVANNI BARBIERI'S DESIGN IS NOW ARRIVE TO OFFER AN INCOMPARABLE SUPERIOR ALTERNATIVE ON ALL BACKLIT ONIX, SEMIPRECIOUS STONE STONE CONCEPTS WALL AND FLOOR SOLUTIONS BY OFFERING AN UTTERLY UNIQUE AESTHETIC AVAILABLE IN INFINITIVE VARIETY OF COLOURS, PATTERNS AND DIMENSIONS.  
MURANO COLLECTION IS SUGGESTED TO BE INSTALLED ON INTERIORS BY AVOIDING INTERIOR SHOWER WALLS AND SIMILAR AREAS, ONLY.  
THEY ARE SUPPLIED INSTALLED ON TEMPERED OR STRATIFIED GLASS ALSO SUITABLE FOR SMALL SIZES WITH LED BACKLIT SYSTEM INCLUDED EVENTUALLY.

## THE MURANO COLLECTION

is Award winner of



THIS PRESTIGIOUS AWARD IS GIVEN BY  
INTERIOR DESIGN, AMERICAN MAGAZINE.

- ON DECEMBER 3, 2015 NEARLY 1,000 PEOPLE FROM THE DESIGN COMMUNITY (DESIGNERS AND MANUFACTURERS) GATHERED AT THE STATE-OF-THE-ART FRANK GEHRY DESIGN, IAC BUILDING IN NEW YORK CITY.
- THE AUDITORIUM WAS STANDING ROOM ONLY, AS THE WINNERS WERE ANNOUNCED LIVE BY HOSTS CINDY ALLEN, EDITOR IN CHIEF, AND CAROL CISCO, PUBLISHER.
- THIS YEAR, THE BEST OF YEAR AWARDS CELEBRATED ITS 10TH ANNIVERSARY AND HAD OVER 300 SUBMISSIONS FOR THE BEST IN 10 CATEGORIES, CELEBRATING THE BEST IN DESIGN FROM THE PAST DECADE
- THERE WERE OVER 1,800 ENTRIES IN 142 CATEGORIES. NEARLY 60,000 VOTES WERE CAST FOR PRODUCT BY THE A+D INDUSTRY.

## SUGGESTED DESTINATION USE

- WALL DECORATIVE .INTERIORS RESIDENTIAL-COMMERCIAL
- BATHROOM/SPA INTERIORS WALL
- (SUITABLE IN LOW HUMIDITY AREA, NOT INSIDE A SHOWER OR SIMILAR).
- YACHT DECORATIVE INTERIORS WALL

NOT FOR EXTERIOR USE.

Foussana Marble, Italian brown handmade terracotta with Dark Grey Murano Glass polished relief inlay



Backlit off

Backlit ON



## SAINT GERMAIN

Carrara, Calacata and Thala Grey Marble with White Silk and Opaline Murano Glass polished relief inlay  
Panel size 38" x 38"  
( 96 x 96 x 2 cm )

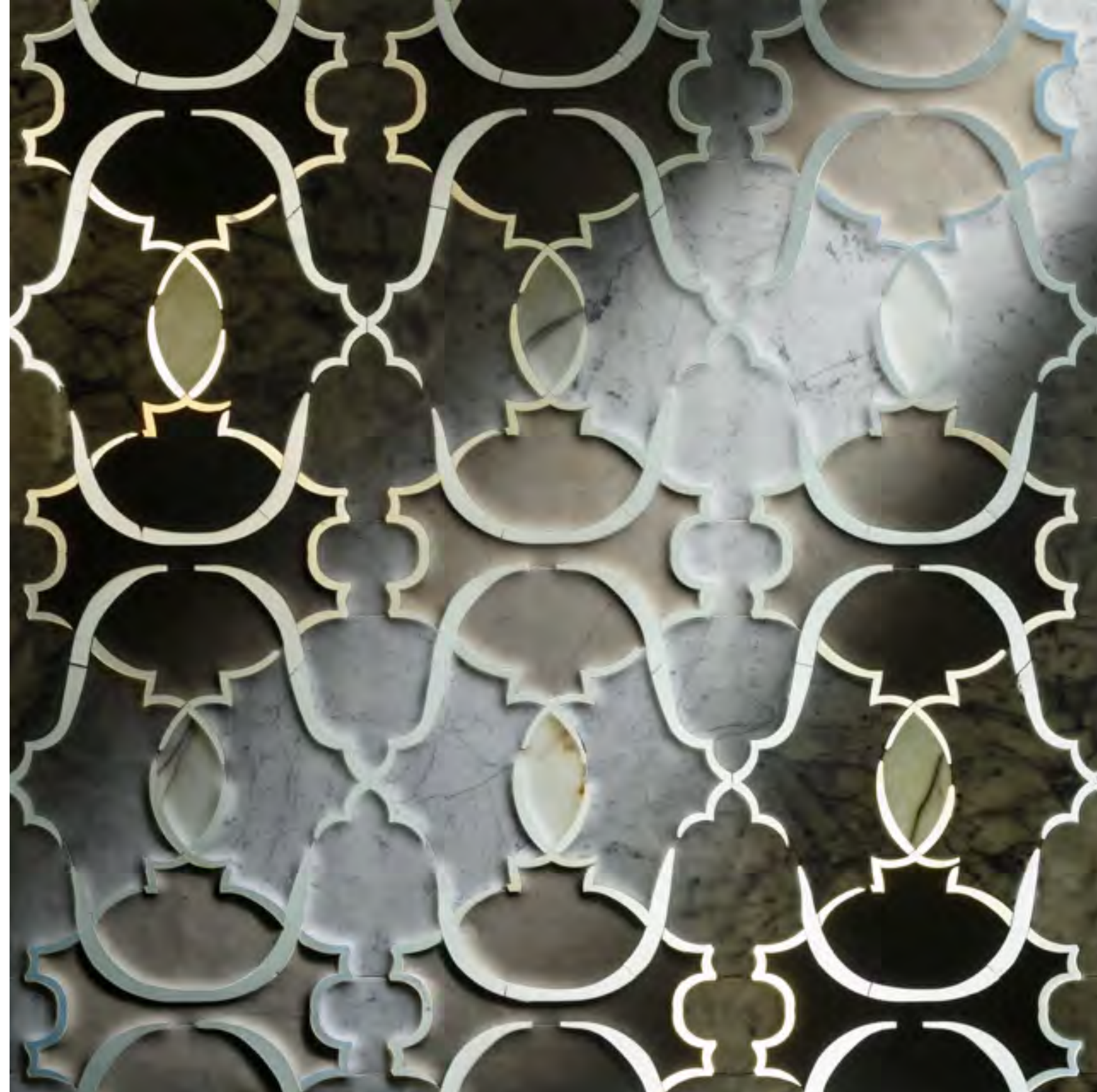





Grey and black Tuscany hand-made terracotta with dark grey Murano Glass polished relief inlay ( just half panel is backlit ).

Only the Murano Glass giving this colourful effect once backlit

**SAINT GERMAIN**  
Black and Grey Italian handmade terracotta with Murano Glass polished relief inlay in dark grey ( become almost white when backlit ).

Panel size 38" x 80"  
( 96 x 200 x 2 cm )





## OBLIO

Grey and Black Italian handmade terracotta  
with polished relief inlay in dark grey  
Murano Glass ( become almost white when backlit )  
Panel size 38" x 38" ( 96 x 96 cm )





## CLAS

15 x 25 Cm modular shapes or fit to size

Brown/Grey handmade terracotta &  
Foussana, Thala Grey, Beige Avorio Marble  
Dark Grey Murano Glass  
that become mostly white when backlit

Mixed surface Textures Honed/ polished  
Panel size 38" x 38" (96 x 96 x 2 cm)





## HEX

Grey and Black Italian handmade terracotta  
with polished relief inlay in dark grey  
Murano Glass ( white when backlit )  
Panel size 38" x 38" ( 96 x 96 cm)

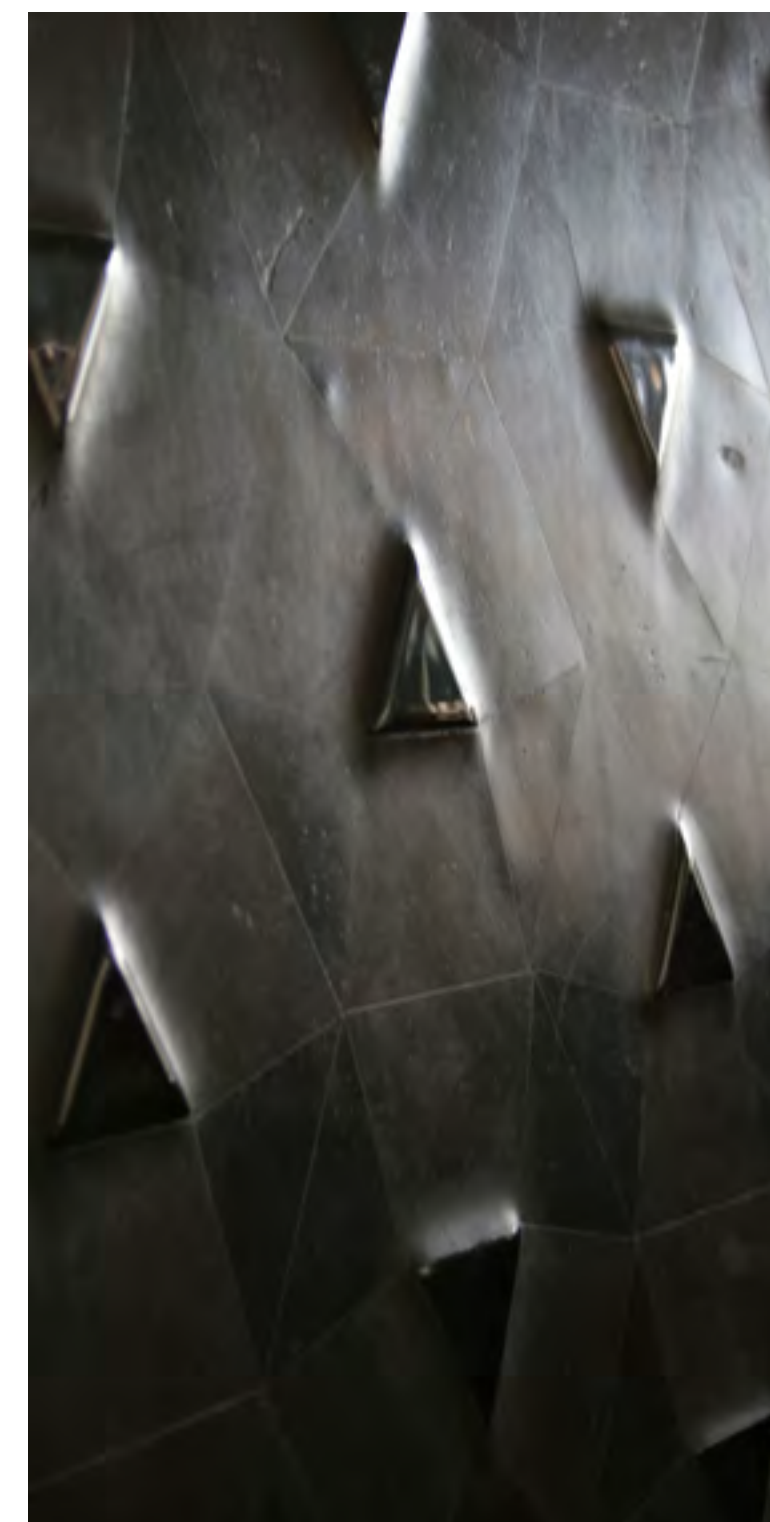



Wall installation size 13' x 9' ( 396 x 275 cm )



## DNA

Italian limestone or handmade terracotta  
with polished relief inlays  
in multicolours or monochromatic translucent Murano Glass



Khaki Terracotta + Dark grey Murano glass polished relief inlays.



## FLORA

Light Beige Italian handmade terracotta  
Bianco Antico Marble and  
polished relief inlay in white silk Murano Glass



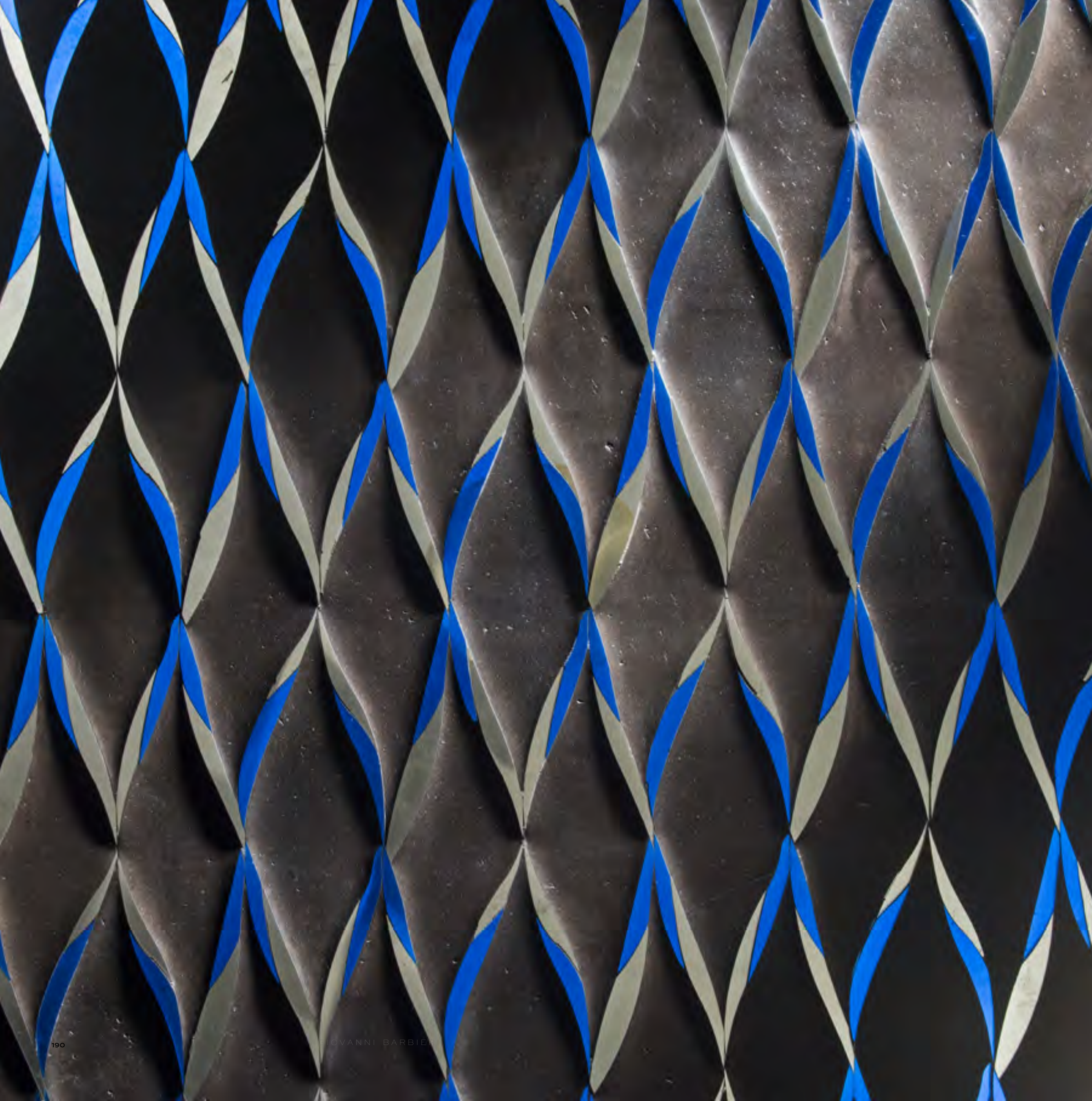

## SIN Blue

Black Italian handmade terracotta with  
Blue Cobalt & Dark Grey Murano Glass  
polished relief inlay

Panel size 38" x 38" ( 96x96 cm )



## TEFI

Grey Italian handmade terracotta,  
with 8 different Murano Glass polished relief inlay  
Panel size 38" x 38" ( 96 x 96 x 2 cm)







## HERAMOSA

Red Travertine,  
Red reclaimed venetian handmade terracotta,  
amber Murano Glass polished relief inlay  
with gold leaf dot Insert  
Panel size 38" x 38" ( 96 x 96 x 2 cm)

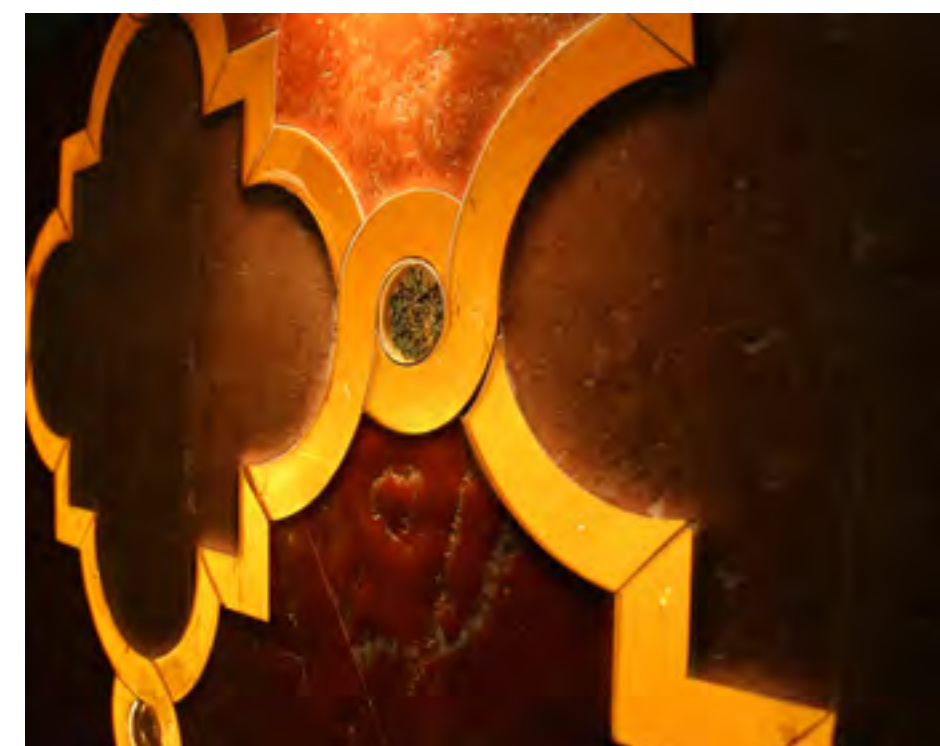

Backlit.



Lighting enhancing the surface relief.

## NOTREDAME

Light Beige / Khaki handmade terracotta,  
Aorio Marble with White Silk Murano Glass polished relief inlay  
Panel size 38" x 38" ( 96 x 96 x 2 cm)



Lighting enhance surface relief.



Full backlit.

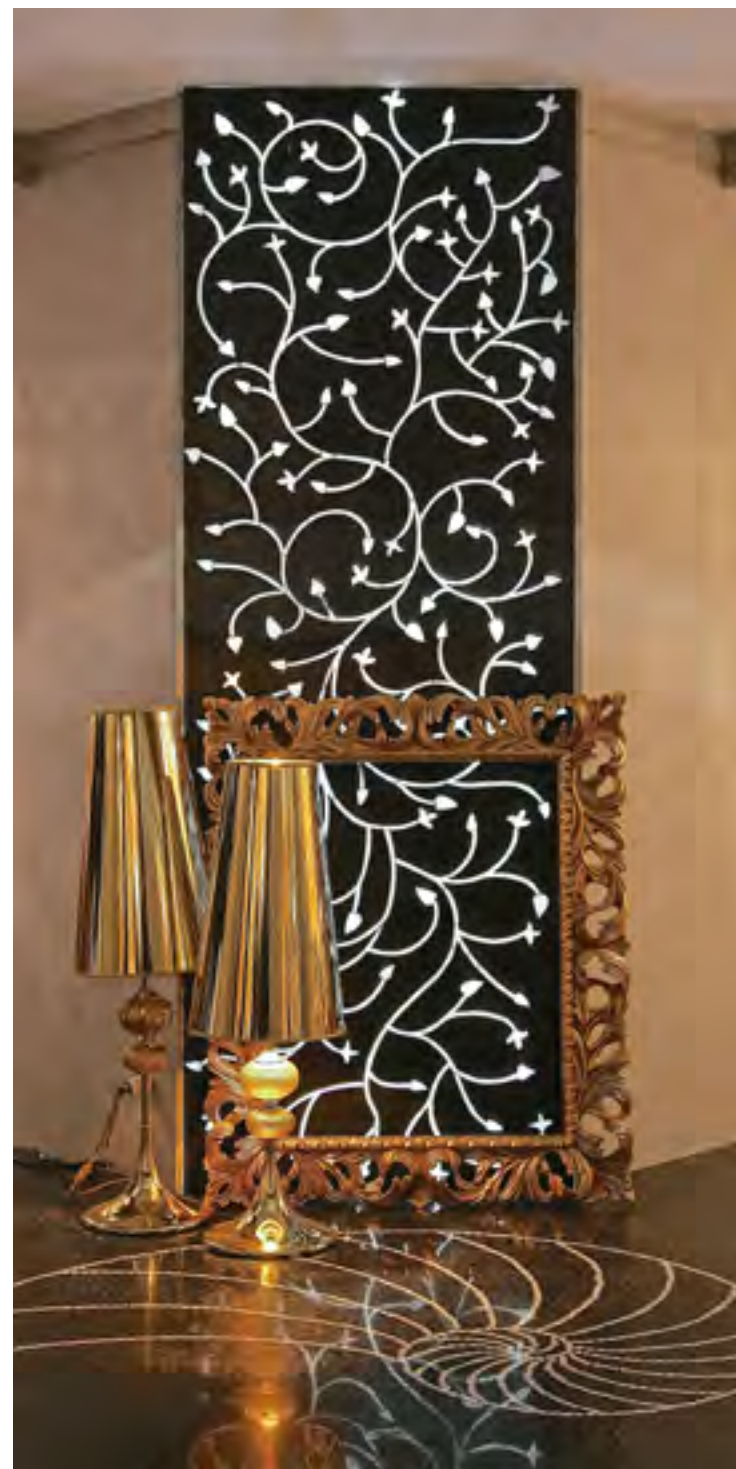

Khaki hand-made Terracotta,  
& Amber Murano Glass.

black hand-made Terracotta /White Silk Murano Glass







Grey Italian handmade terracotta, polished relief inlay in transparent Glass with silver leaf applied on the bottom on each single piece.

**SOPHIE**  
design by Sara Baldwin

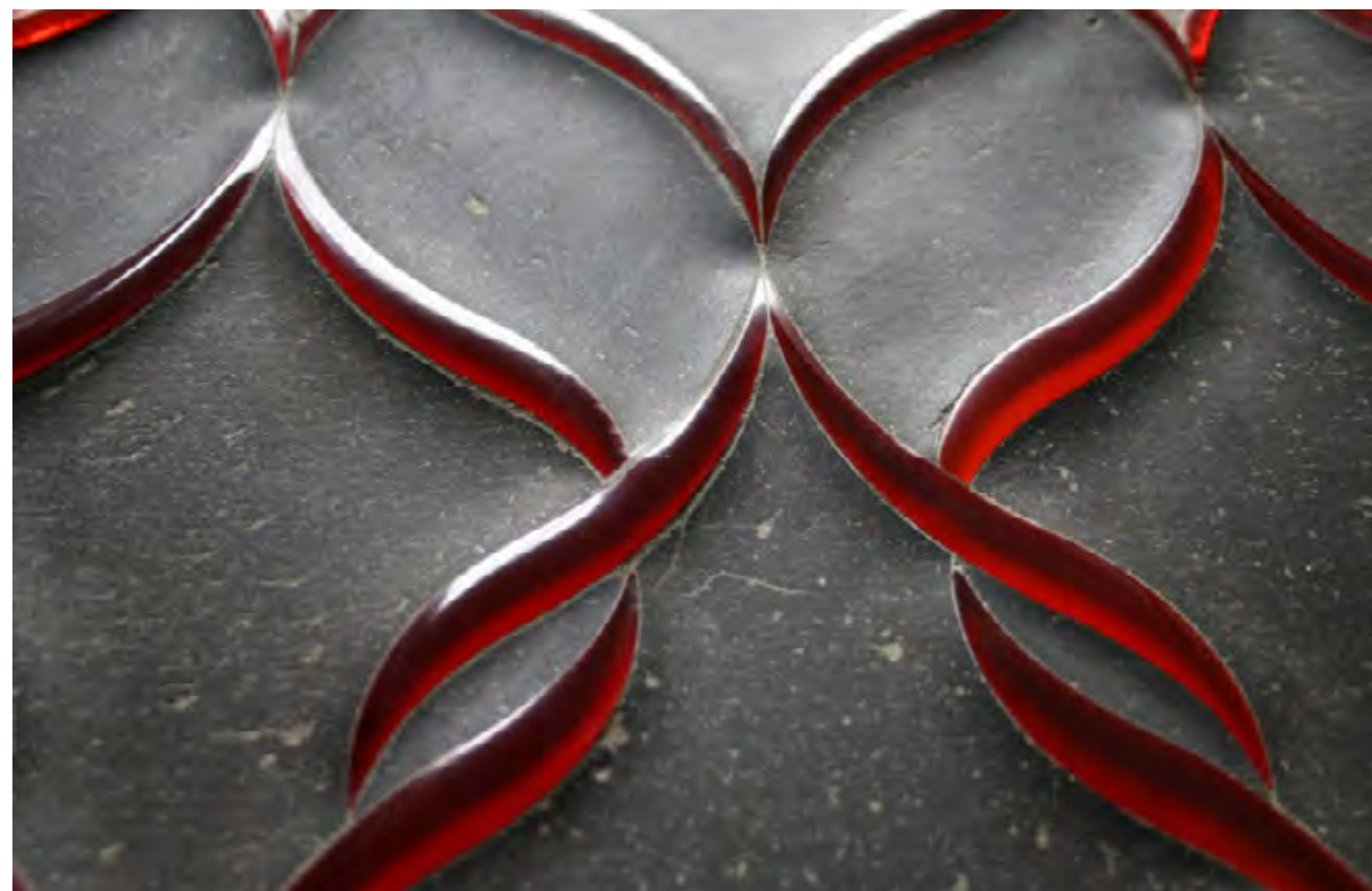

Grey Italian handmade terracotta, with red rubin Murano glass polished relief inlay.



# ART WORK

in cooperation with  
Roberto Lanaro Metal Sculptor

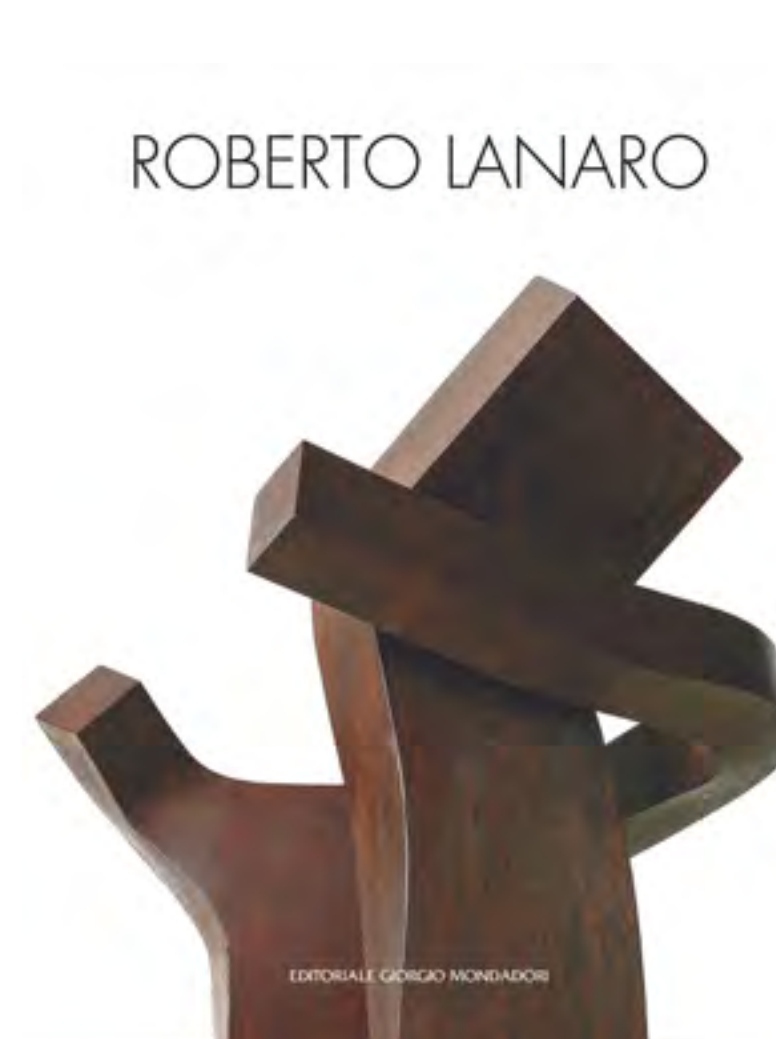

“Works of art are mirrors  
in which everyone sees reflected  
what resembles him”

Costantin Brancusi





“Sinuosity & Dots”  
 24” x 24” x 3/8 ( 61 x 61 x 1 cm )Brass  
 and natural Stone handmade  
 12 pieces Limited Edition



“Core”  
 Diameter 24” x 3/8 (61 x 1 cm)  
 Brass and natural Stone  
 handmade  
 2 pieces Limited Edition

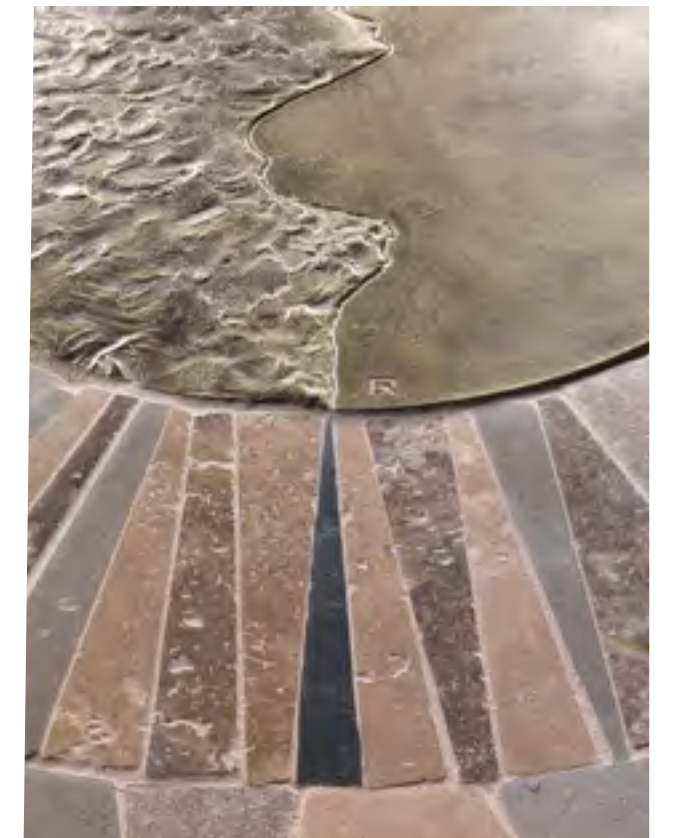



“Framenti Sinuosity”  
 24” x 24” x 3/8 ( 61 x 61 x 1 Cm)  
 Stainless Steel and  
 8 different Carrara  
 Calacatta marble  
 12 pieces Limited Edition



“Conjunction”  
 24”x 24”x 3/8  
 ( 61 x 61 x 1 Cm )  
 Brass and  
 8 different  
 yellow-beige  
 Natural Stone  
 12 pieces  
 Limited Edition



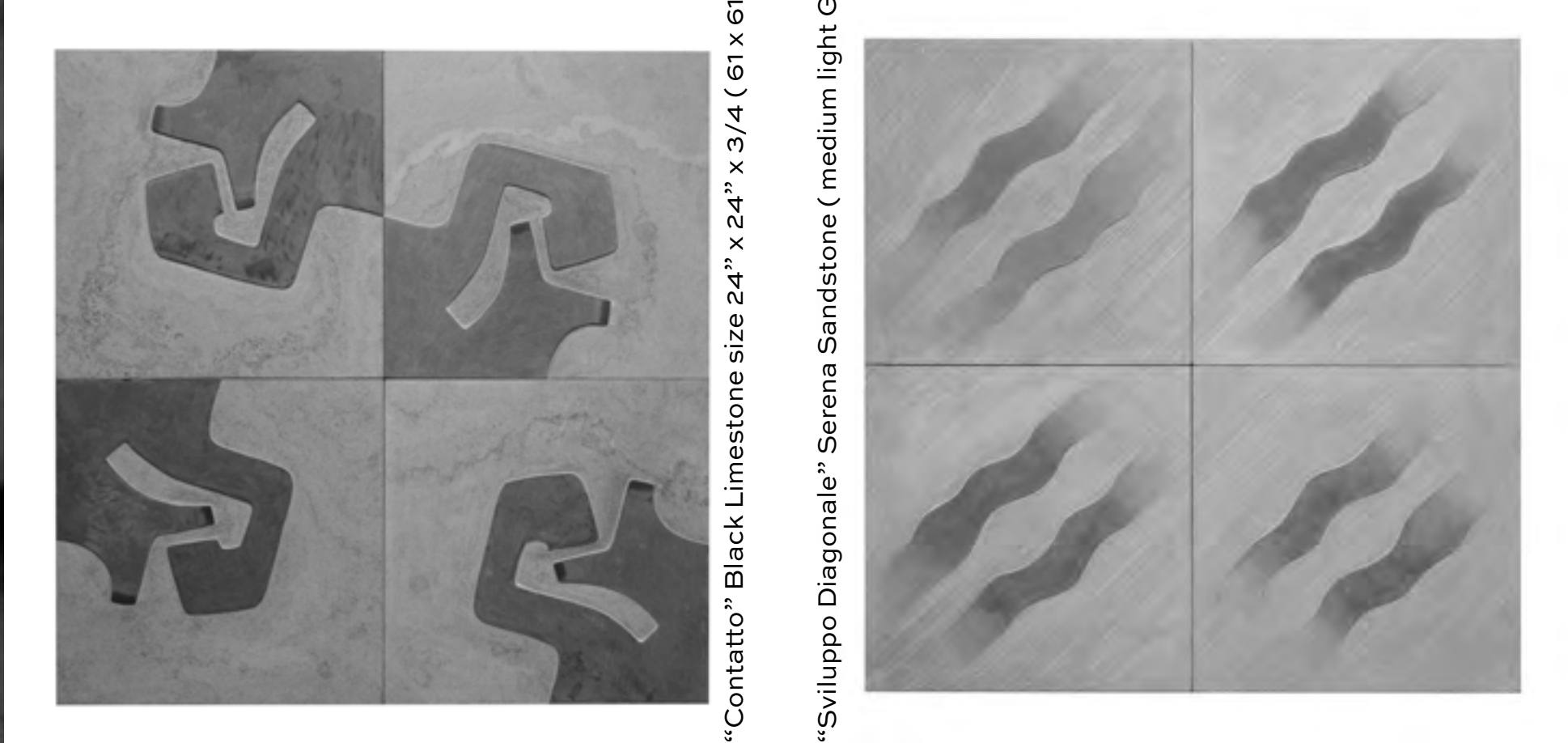
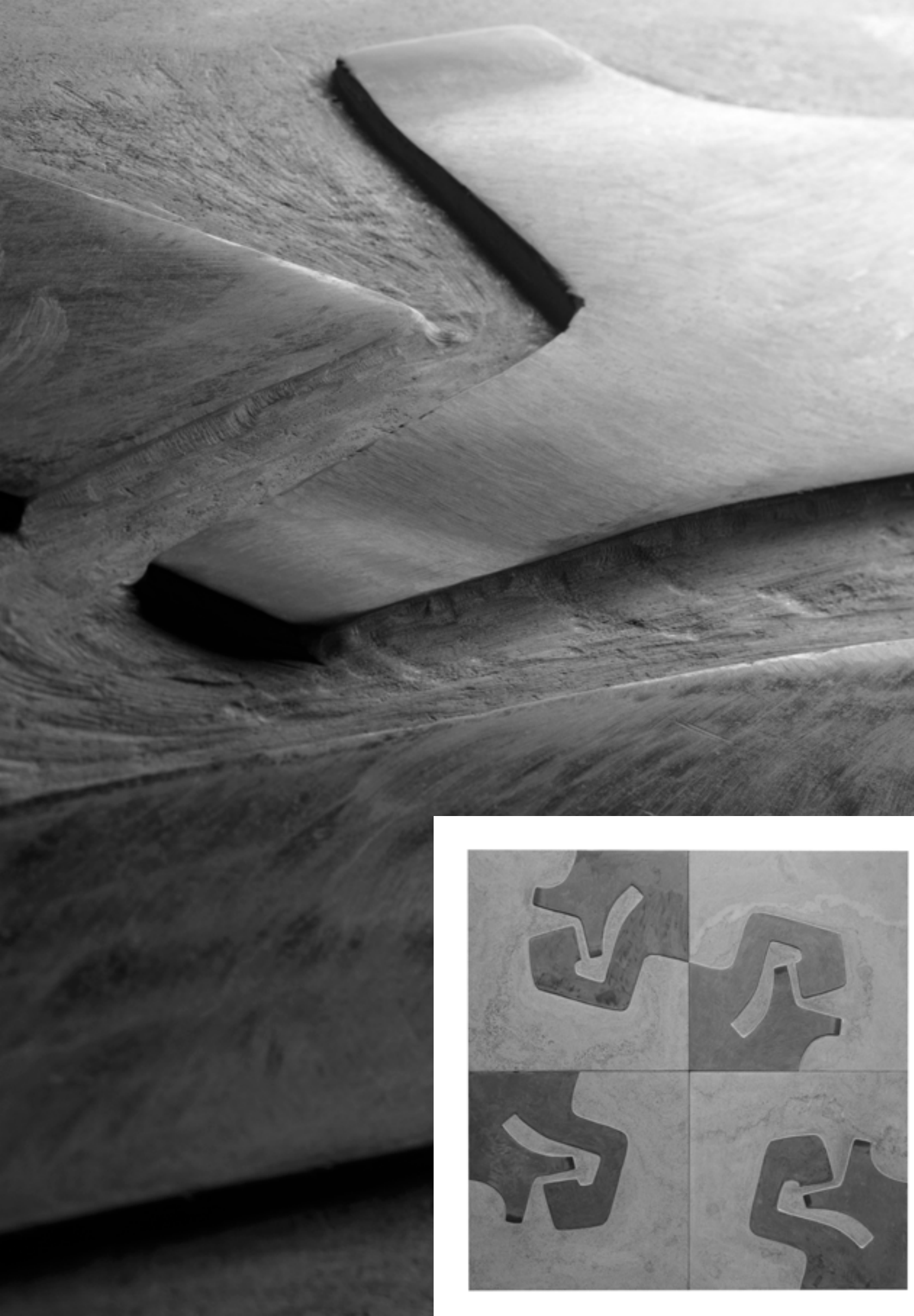

“Contatto” Black Limestone size 24” x 24” x 3/4 ( 61 x 61 x 2 Cm ) 12 pieces Limited Edition.

“Sviluppo Diagonale” Serena Sandstone ( medium light Grey) size 24” x 24” x 3/4 ( 61 x 61 x 2 Cm) 12 pieces Limited Edition.

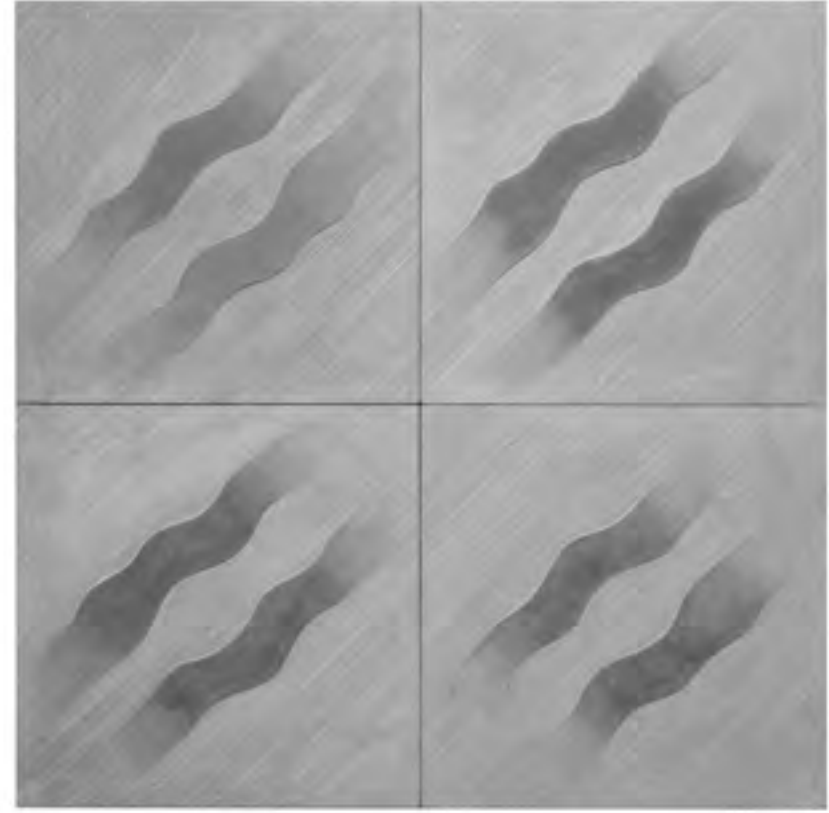



"Trama Continua"  
24"x 24"x 1/8  
( 61 x 61 x 0,5 Cm )  
Stainless Steel  
6 pieces  
Limited Edition



# AWARDS



# B I O G R A P H Y

Giovanni started his career at the age of 14, working in the marble sector as a go-getter.

By the time he was 16, he was capable of completing floorings by himself for his older brother's business.

In 1984, at the age of 18, Giovanni contributed 50% of the investment and entered into a business partnership with his brother by establishing F.LLI Barbieri.

By then, the company had already started producing tumbled marbles for its own projects.

At the age of 22, Giovanni started attending school courses in interior design from 1989 to 1997.

His best results were achieved on building site projects – projects where he worked together with the architects who taught the classes.

These collaborations reinforced a period of strong progression: Giovanni was the only project developer and supplier of marble tiles that came exclusively from the Family Stone company and personally supervised the installations.

The emphasis was placed on the production process and the design of new products; first for the local market, then all the way to the United States, thanks to the excellent understanding of design, research and development and the excellent long-standing collaboration with Nancy Epstein.

Many patents were developed in the late 90's such as "MARMO ANTICO LUCIDO"; "FRAMENTI BORDER"; "TIMEWORN MARBLE" and more were to follow.

Giovanni participated in various Contemporary Art Competitions receiving a special mention in Torino in 2003 with Roberto Lanaro, a renowned European Metal Artist-Sculptor.

In 2008, "AMBRA COLLECTION" received an American Architecture award and was featured at "Triennale Design Museum" in Milan for more than a year.

In 2010, Giovanni started his successful collaboration with Sara Baldwin developing irreproducible Timeworn Mosaics a best seller after 13 years, as well as Ambra.

Giovanni Barbieri has been a source of inspiration for many renowned brands resulting in the successful reproduction of his inventions and Techniques; AMBRA is an example reproduced by many.

In 2013, the first Engineered 3D Marble Tiles Collections Exciton/Hive was awarded at Best-Of-Year INTERIOR DESIGN.

This Collection is produced by recycling marble dust from production waste for high performance installation where natural stone is not preferred.

In 2013, the Memento Porcelain Tile Collection was Best-of-Year INTERIOR DESIGN Award-winner with Vallelunga Ceramica.

In 2014, Giovanni was the Winner of the London Surface Design Award with "CLAS" on Belgian project.

2015 is the year of the Murano Collection; Award Winner at Best-Of-Year INTERIOR DESIGN, NYC.

In 2016, the world's first true 3D porcelain tile collection "TRILOGY", winner of BoY INTERIOR DESIGN, was presented in the USA and at New York City Design Award in May 2017 at the MoMa in NYC.

2017 marks the launch of new shading flat 3D wall tiles: "Collection RR".

In 2018, a new chapter begins with new Antiqued handmade Black terracotta tiles in an "easy-care" version: the "Minimal Rustic Collection".

2018-19-20 was the initial success of the first version of SQUAR[E] Collection, between the tile collection and Art performance, it won triple awards in the USA also at the BoY Awards, and by ARCHITECTURAL RECORD USA Magazine also with the handmade ceramic tile collection "KLE".

2020 is over and the Terrazzo Collection "The Fine Lines" was nominated Overall Winner at SBID (The Society of British International Interior Design) product design Awards in London.

INTERIOR DESIGN USA: Best of Year Awards nominated Giovanni one of the four best Product Designers.

The Fine Lines Terrazzo Collection won a Boutique Design New York International Design Competition in the Floor Covering Category.

On 2021 March, Squar[e] ceramic tile size 2" x 2" 3/4 received the Red Dot Product Design 2021 Award.

The Fine Lines Terrazzo is Award winner at last 17th Hospitality Awards in NYC at Cipriani NYC Event last September 21st, thanks a marvellous cooperation with the excellence in Terrazzo handmade 3rd generation family of Laboratorio Morsetto in Vicenza.

Depthile Carrara Marble tiles has been installed on INTERIOR DESIGN Best Of Year Award Winner project/Bath by Snorre Stinessen in Norway.

On 2022, "Le Piastrelle Segnate" designed for Fornace Brioni, become the Red Dot Design Best of the Best Award winner, probably the most important European product design award, established in 1955.

2023 started beautifully with the receipt of the third Red Dot Product Design Award, Best of the Best with Blooming wood parquet system collection.

2023 "Le Piastrelle Segnate" has been the winner/nominated 2023 best tile design by Luxe Magazine in USA. Thanks to Cle' Tile, Nord America distributor.

