

INDEX

DESIGNER	7
COLLECTIONS	
CERAMICS	
TRILOGY	9
PATCH	29
RR	43
SQUAR	49
LA PIASTRELLE SEGNATE	63
STRALLERI	79
REGOLI	85
CONTEMPORAINE	95
SOLID MOSAIC	99
DEPTHILE	107
TIMEWRON MARBLE MOSAIC	119
THE FINE LINES	151
THE MOSAICO	157
CUSTOM MADE PROJECTS	163
THE MURANO COLLECTION	167
WOOD PARQUET DESIGN	
BLOOMING	193
COLLABORATIONS	
ARTWORK WITH MR LANARO	207
AWARDS	217



Giovanni Barbieri is an Italian artisan and designer renowned for his groundbreaking work in decorative surfaces. Merging tradition with innovation, this master artisan with years of experience reinvents stone craftsmanship through unique textures, patterns, and advanced techniques. Giovanni Barbieri began his career in the marble sector at age 14, advancing to independently completing flooring projects by 16. Barbieri's collaborations with top architects and designers showcase his ability to push creative and technical boundaries, making his work highly sought after worldwide. He has received numerous international awards for his innovative stone designs, including recognition from the Red Dot Design Award and the Interior Design Best of Year Awards.

Credit: Homo Faber Guide presentation / <https://www.homofaber.com/en/guide>

TRILOGY COLLECTION
FIRST 3D PORCELAIN TILES



CINDER





Trilogy by Giovanni Barbieri is an utterly unique product with the following characteristics:

- The world's first three-dimensional porcelain tile measuring 2" deep hexagonal 6" (cm 15,0) side changing its surface thickness from 2/8 to 1_1/2" (8 mm to 38 mm) in just 11" 3/8 (30,0 cm) which represents the largest side of each tile
- This is also the first pattern where a regular hexagonal tile, ease of installation, obtains irregular random shapes thanks to two different joint widths generated during installation
- The fashionable combination of the 3 different textures applied on 3 different color shades in 3 different ways on 3 different models, which need to be installed randomly, complete the latest barbieri utterly unique aesthetic result
- The 3 models permit to obtain on linear pattern and one random pattern installation

- Individual custom accents are available on depth, colours and textures including corners and frame accessories thanks to the customer service of Barbieri design studio
- A new concept of background or just ornamental wall solution in between a traditional flat surface and high structured 3d walls
- Offering an easy maintenance / cleaning surface, also suitable for any lighting and installation accessories.
- Guaranteed for any exterior extreme climate condition, wet area installation or next to high – temperature sources (fireplace wall).

Trilogy is Best of Year Interior Design 2016 Award Winner on 3d wallcoverings Tile&Stone category. NYCXDESIGN Award Winners 2017 on Wall Covering tile Category.

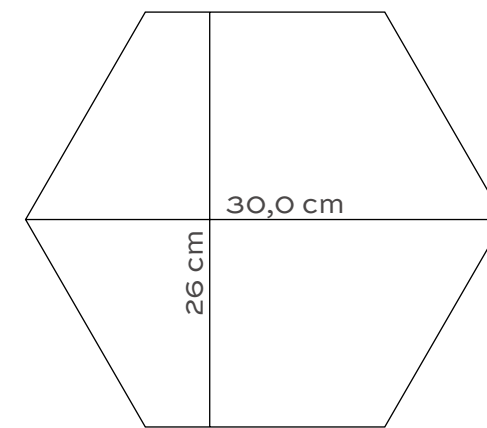
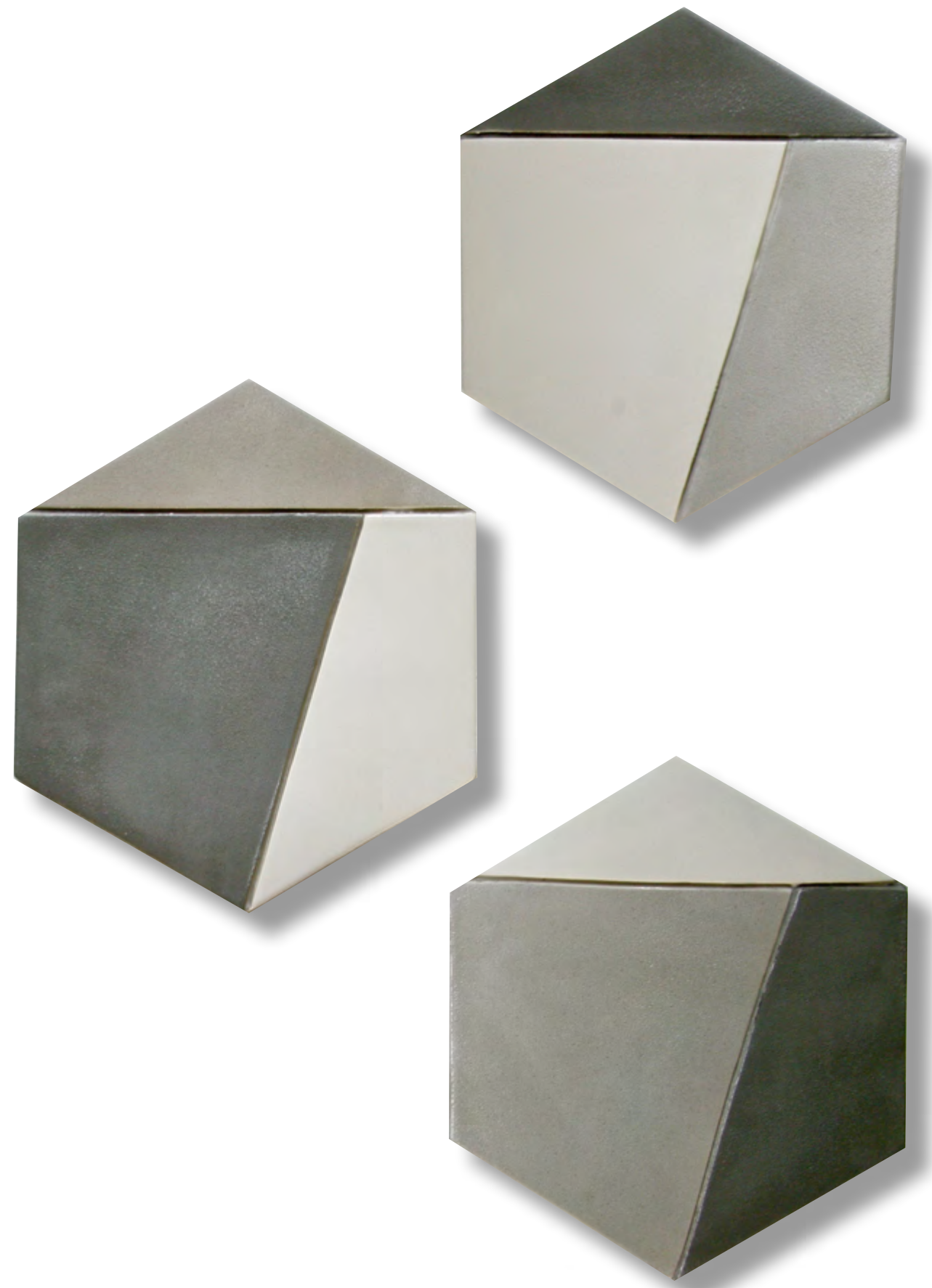

0,0585 sq m x 1 piece
17pcs = 1,0 sq m

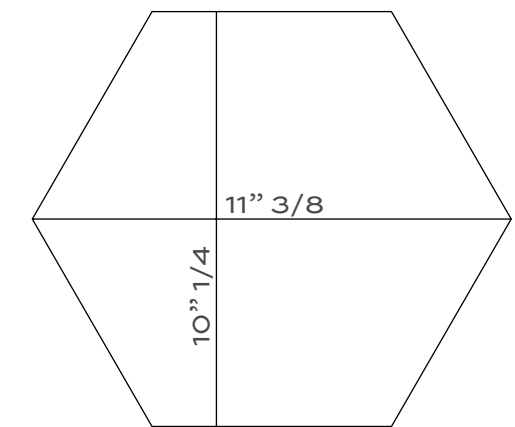

0,63 sq f x 1 piece
1,59 pcs = 1,0 sq f

The fashionable combination of the 3 different textures applied on 3 different colour shades in 3 different ways on 3 different models, which need to be installed randomly, complete the Giovanni Barbieri's utterly unique aesthetic result.

The world's first three-dimensional porcelain tile measuring 1'' 1/2 deep hexagonal 6'' (15,0 cm) side changing its surface thickness from 2/8 to 1_ 1/2'' (8 mm to 38 mm) in just 11'' 3/8 (30,0 cm) which represents the largest side of each tile.

All 3 models/tiles have 3 to 4 mm joint in the middle between the 3 shapes composing each single tile. During the installation, simply align the edge of one tile to the matching (same lengths and thickness) edge of the adjacent tile. This allows a single colour and texture to come together, while being defined by the perimeter larger joint.



The three models can be installed in a linear or random pattern.

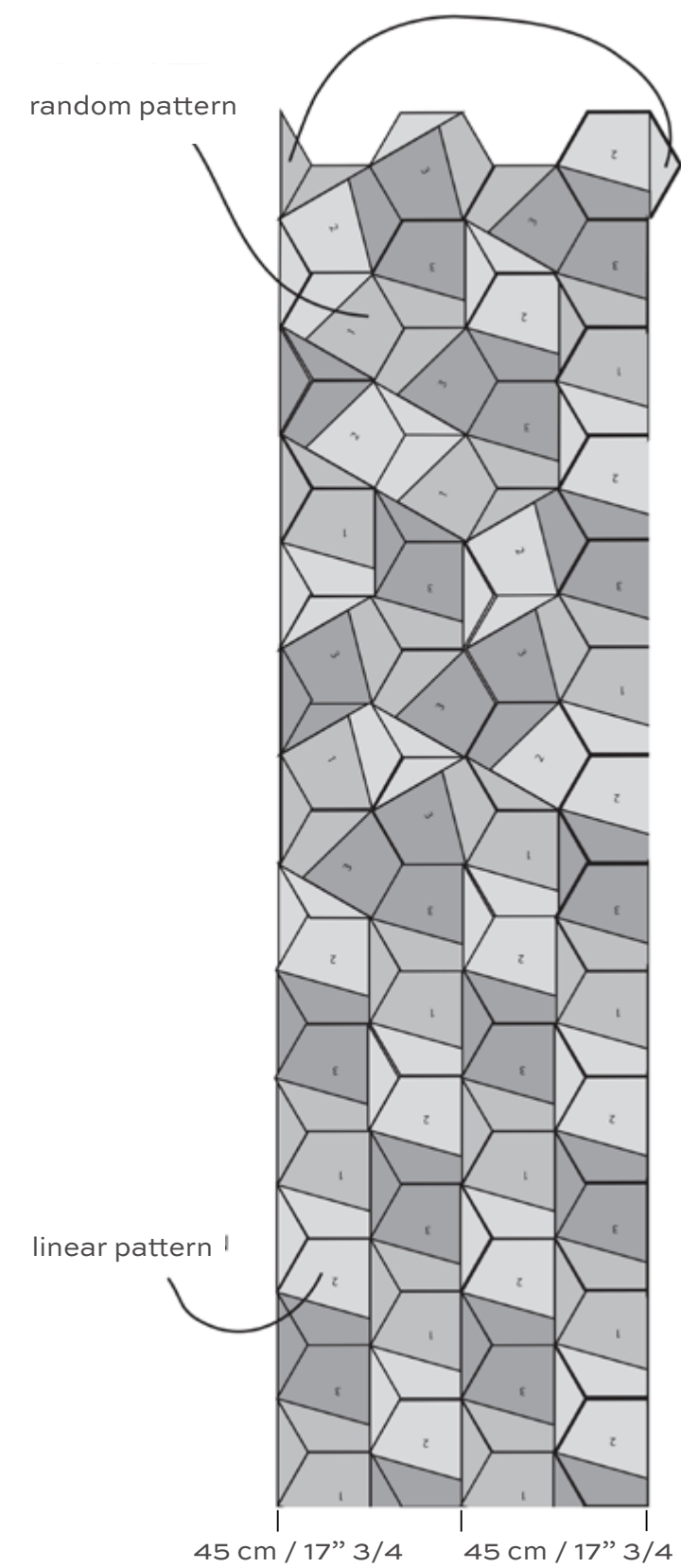

Two patterns on the same wall: triangles are take out for start installation on one vertical side and complete straight on top side with the same in the other side.

ULTRA WHITE



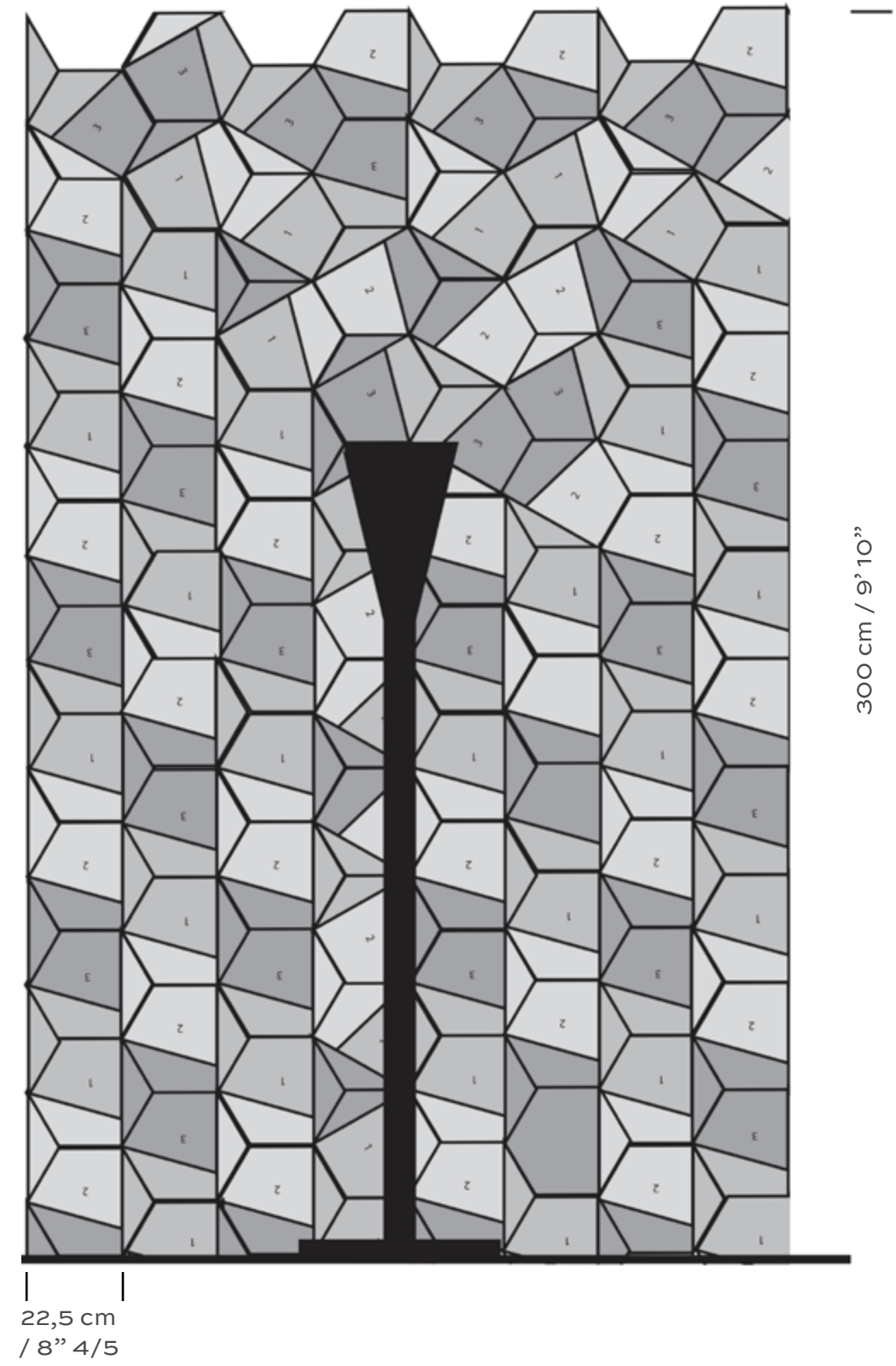

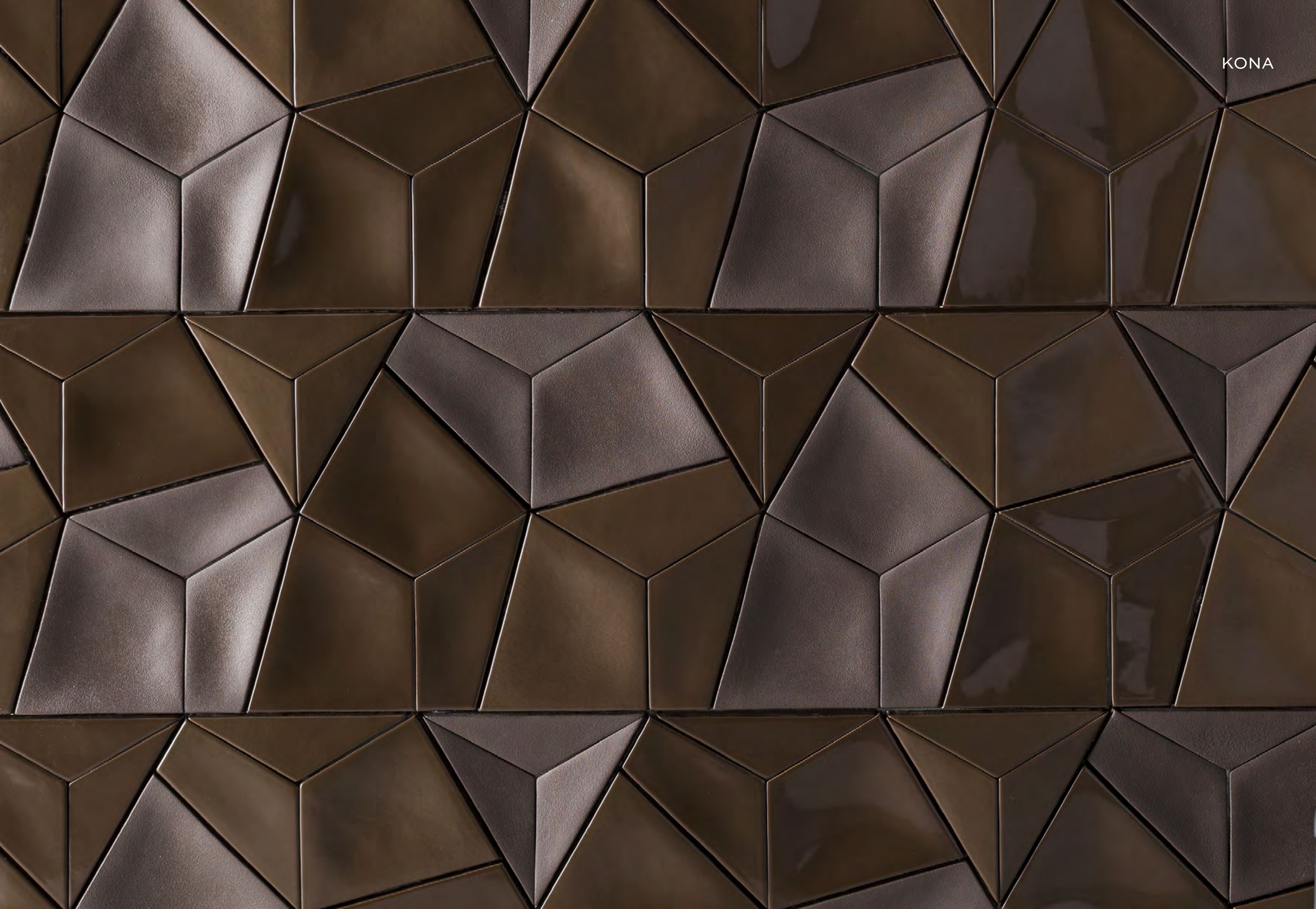

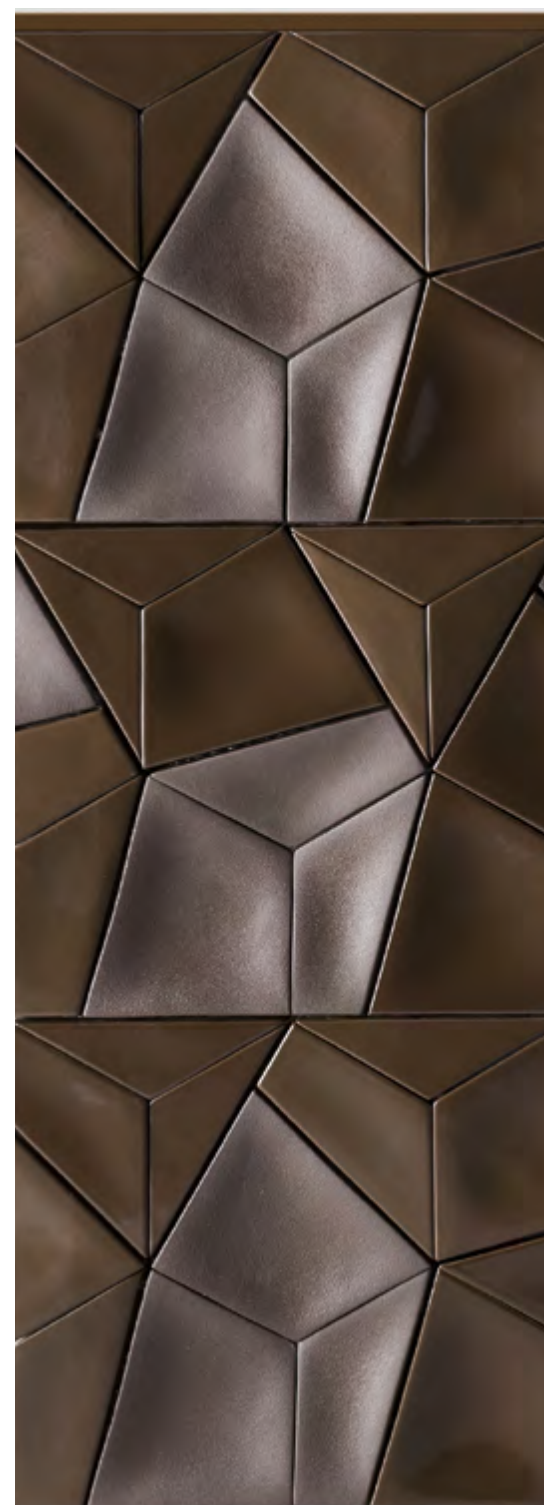

45 cm / 17" 6/8

45 cm / 17" 6/8

45 cm / 17" 6/8

135 cm / 53"



PATCH COLLECTION
HANDMADE VENETIAN CERAMIC TILE



Patch collection is a combination of research & development of geometric new tile shapes, surface texture and colour combinations, production feasibility and particularly great aesthetic results. Patch is 5" $\frac{2}{3}$ x 5" $\frac{1}{3}$ x $\frac{3}{8}$ handmade totally new look of ceramic tiles as never seen before: the purely random installation of the different models obtain a play of deformed square shapes That are always different, with no compare.

DIMENSIONS

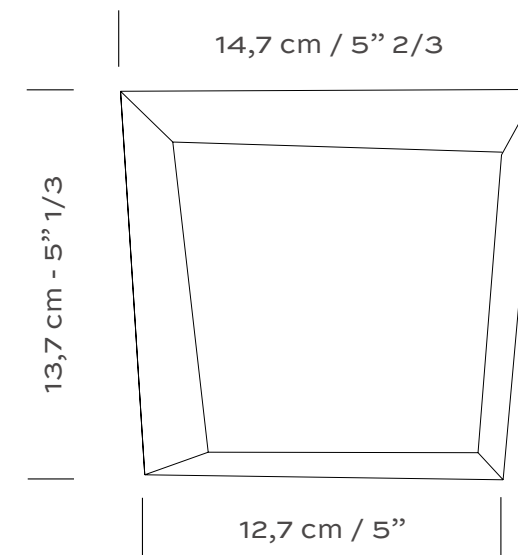

COLOUR VARIATIONS

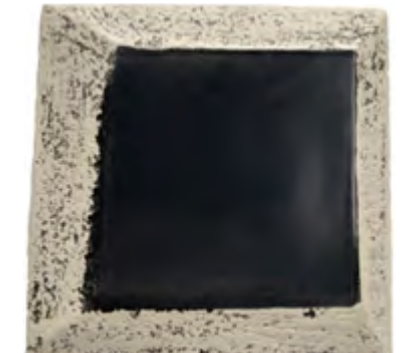

Glossy white texture
beige sides



Glossy white smooth
black sides

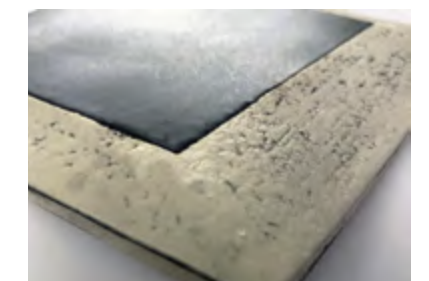

Smooth dark grey
beige sides

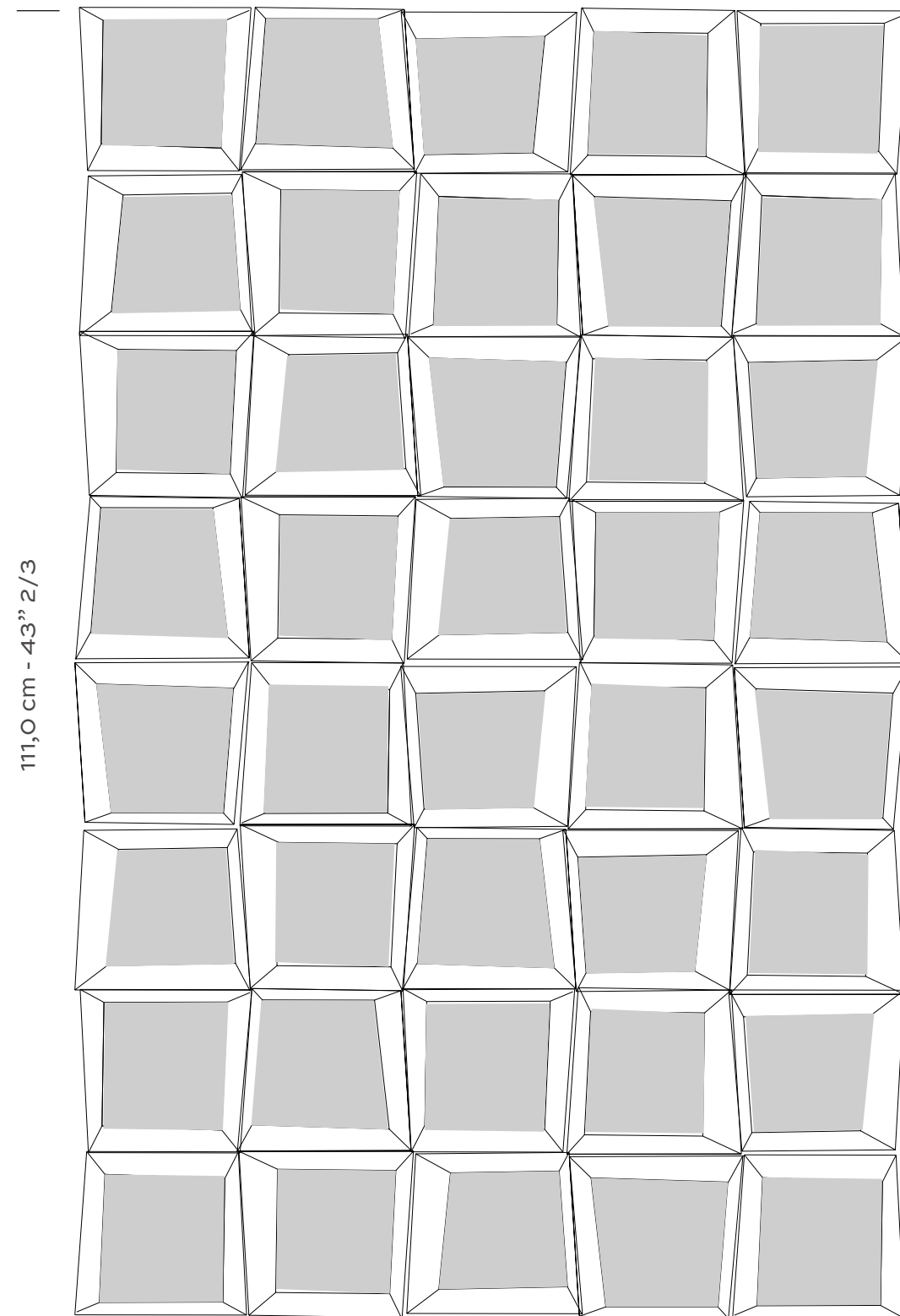

111,0 cm - 43'' 2/3

69,5 cm / 27'' 1/3

5 pcs = 1,0 sq f
53,5 pcs = 1,00 sq m

8 different models

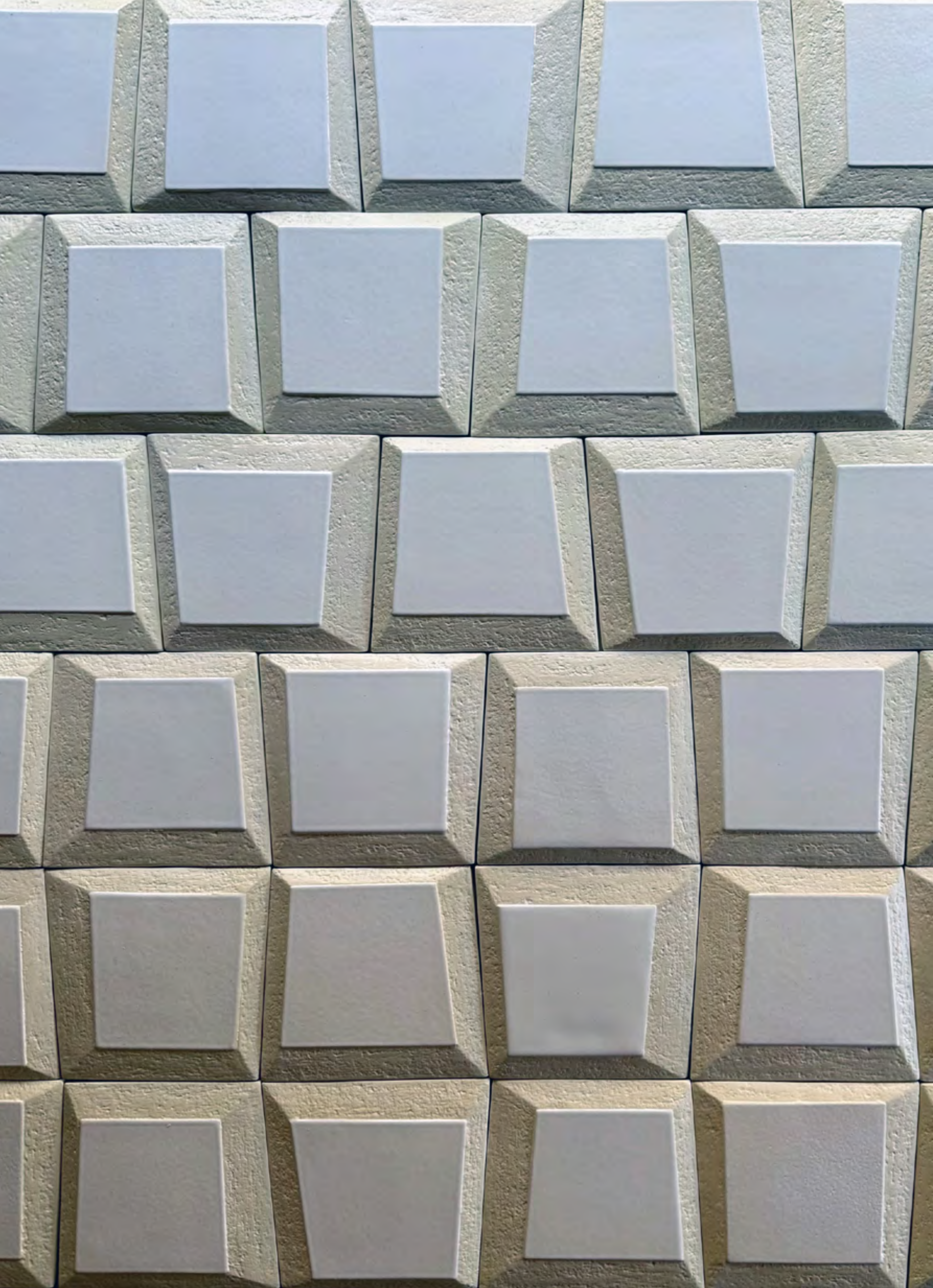

Glossy white texture with
beige sides

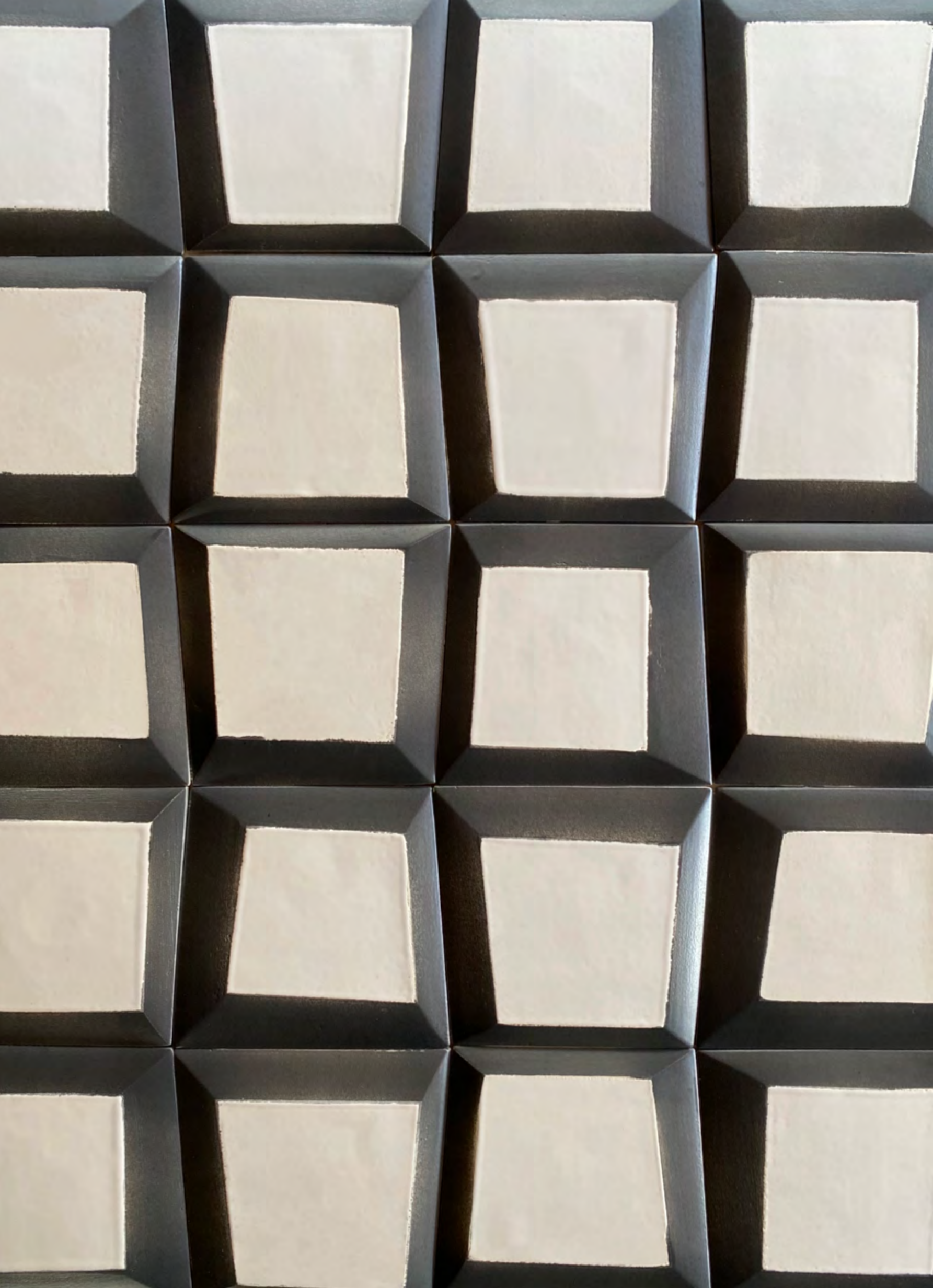

Glossy white smooth
black sides

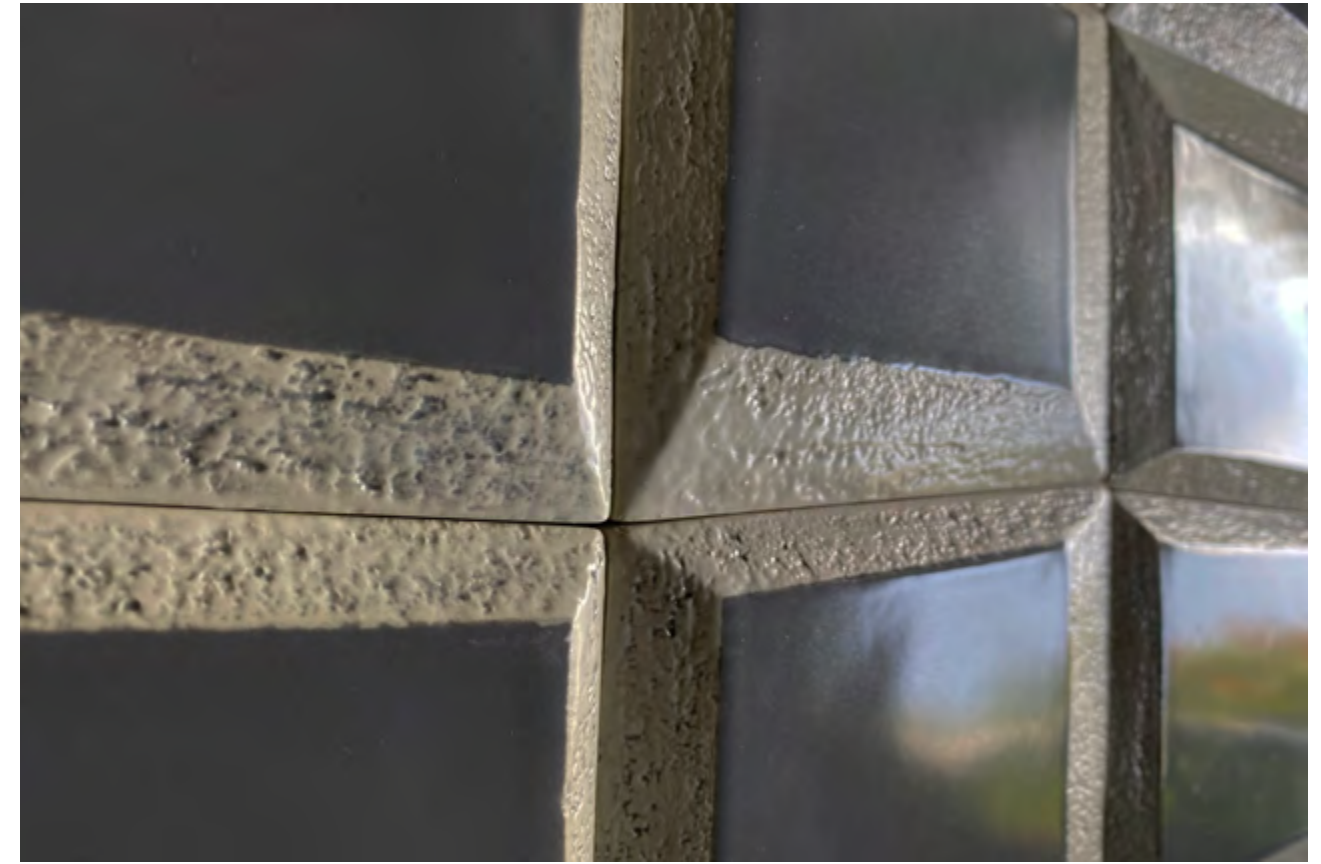

Smooth dark grey
beige sides

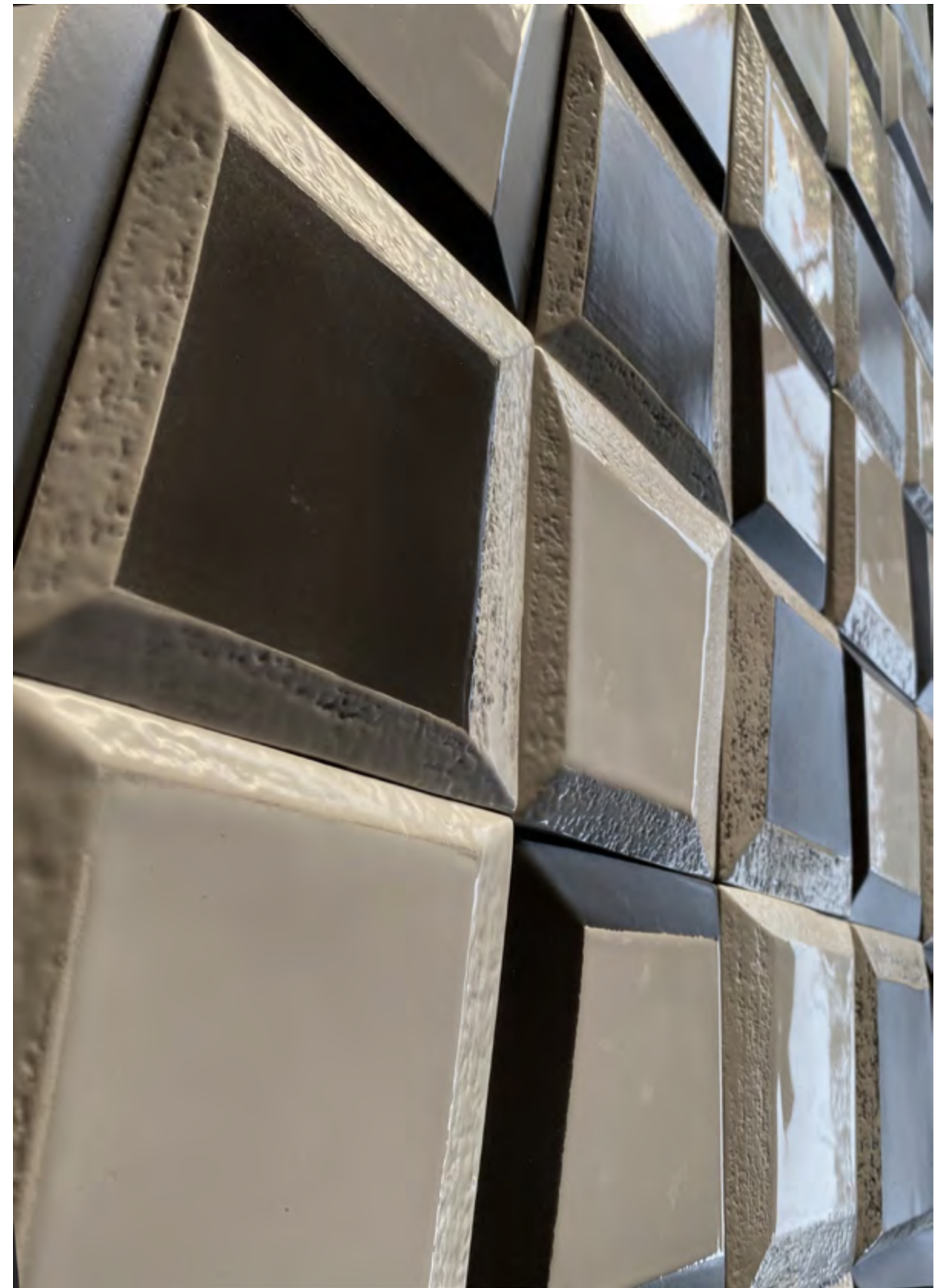
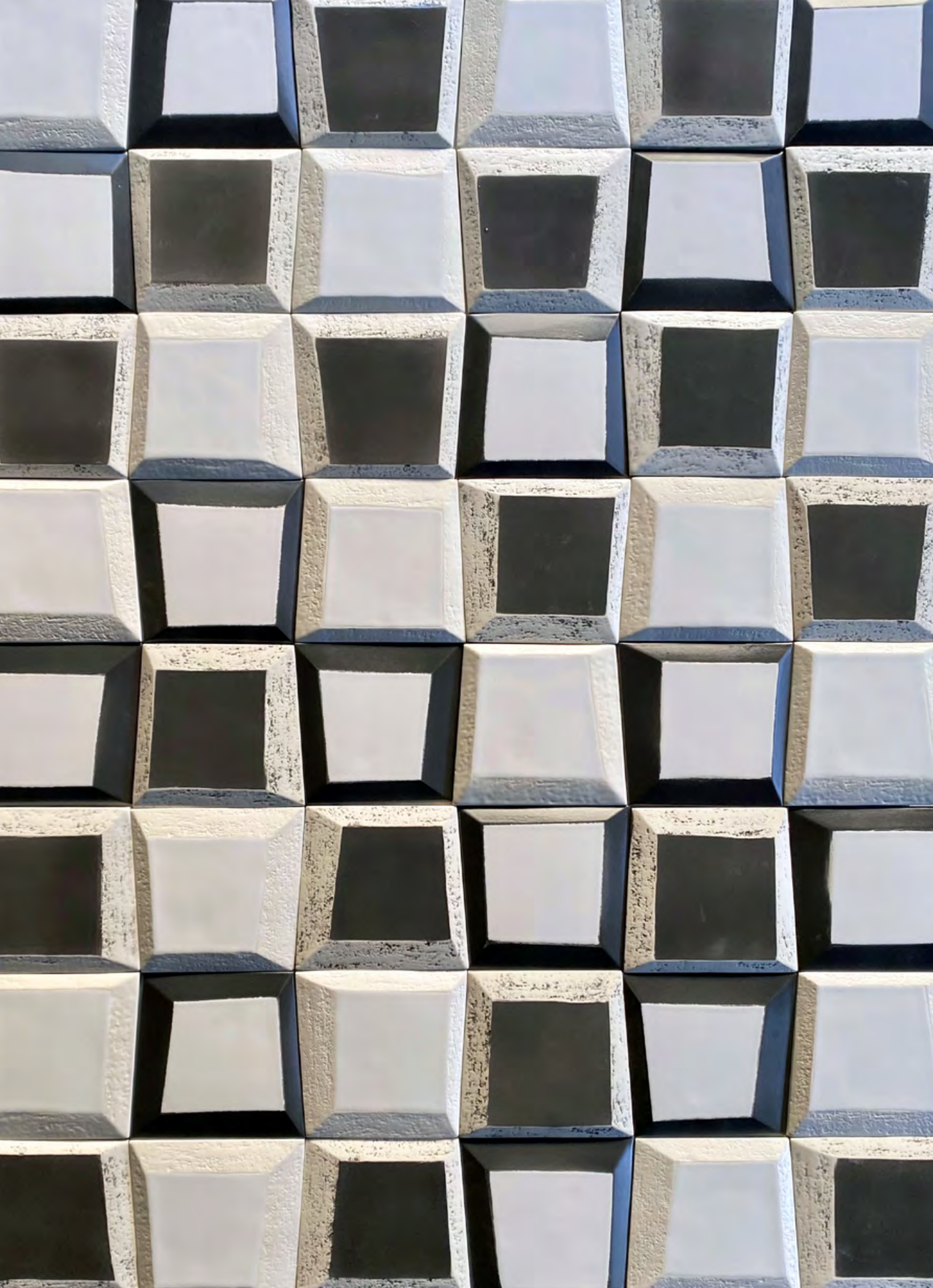

All three mixed

R R C O L L E C T I O N

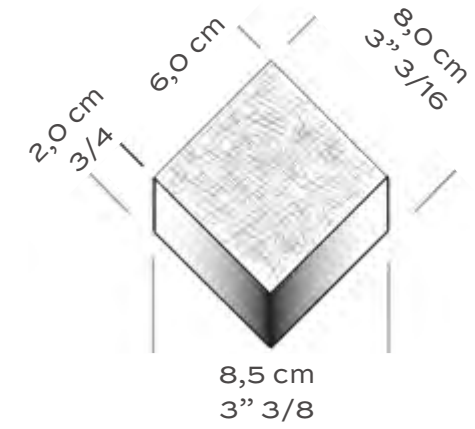
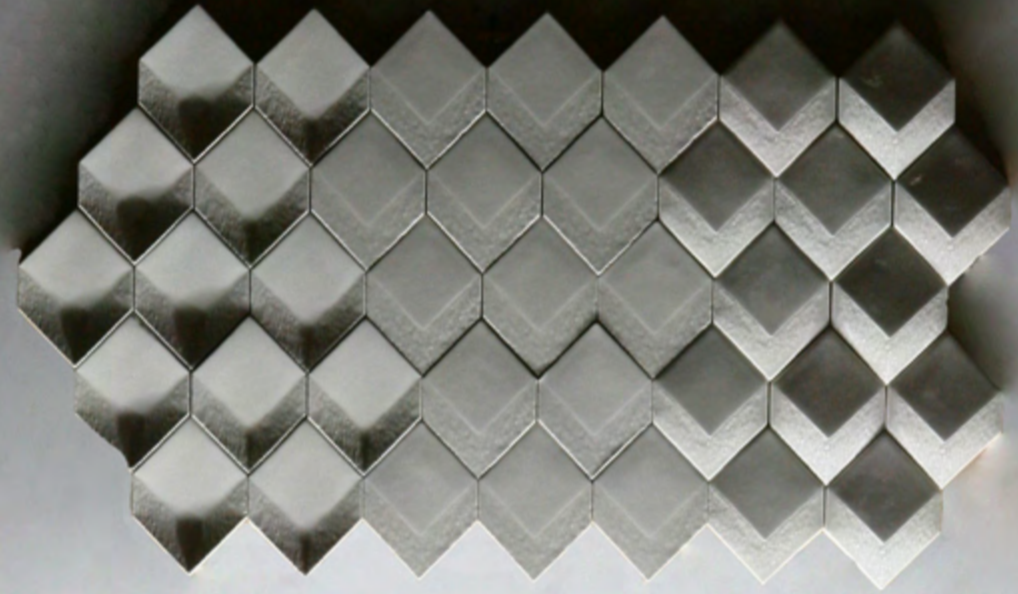

Each mesh mounted panel is composed with 15 tiles:
 36,0x25,5 cm = 0,092 sq m (each panel)
 14" 3/16 x 10" = 0,99 sq f (each panel)
 Shading wall
 From flat to low high carved-convex tiles
 In 5 models



flat



1
medium
carved



2
max
carved



3
medium
convex

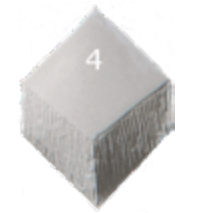

4
max
convex

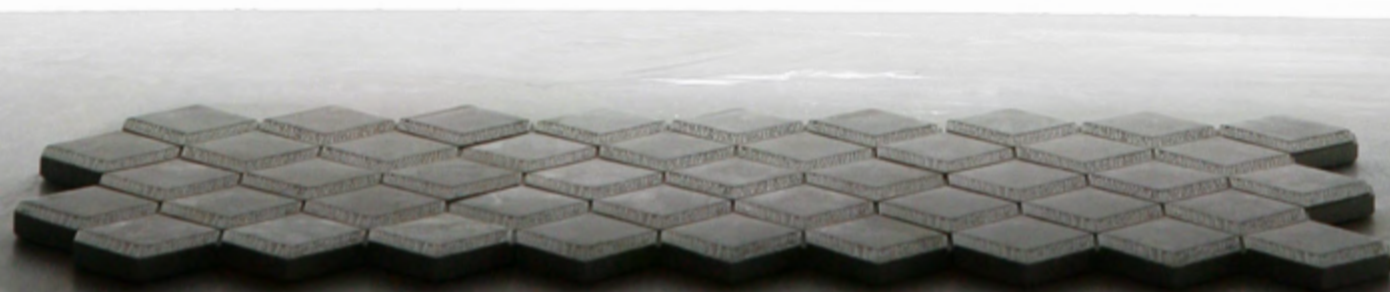

Available in ceramic tile honed or polished surface with hand painted customizable options. Plaster is also available for dry installation/destination use, only, exclusively produced by staffdecor.fr in France.
 For exterior use, and wet area installation a gres version is available in size 7,5x7,5 cm (3" x 3"). Each mesh mounted panel is composed with 15 tiles: surface 33,6 x 23,3 cm = 0,0783 sq m / 13" 1/6 x 9" 1/6 = 0,842 sq f.

Each panel supplied as loose tiles or mesh mounted following a lay out drawing installation. The resulting structures have a highly impressive effect, especially on large surfaces, and create distinctive atmospheres in interiors. The perfectly thought-through design is also highly functional in terms of installation and allows seamless adaptation to individual preferences.



PATTERN INCLUDING
ALL THE 4 MODELS



pattern 1
flat tile only



pattern 2
flat & medium
carved/convex



pattern 3
flat & medium
carved/convex



pattern 4
max
carved/convex

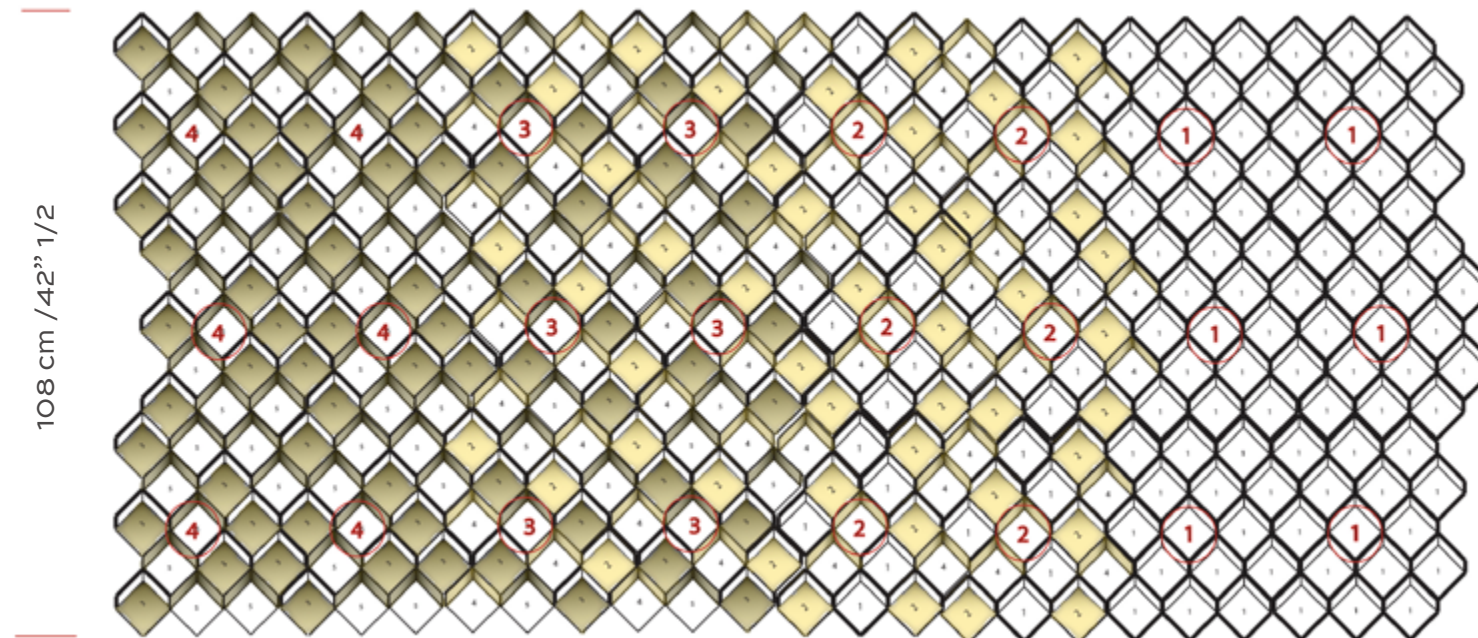

SQUAR

DIMENSIONAL TILES



reddot winner 2021



Surface architecture reaches new horizons with the Squar Collection, a groundbreaking innovation that transforms walls into dynamic, ever-changing surfaces.

Squar redefines wall design, making it free and adaptable—embracing shifts in direction, light, and shade. With a multiplicity of interpretations, it introduces a new paradigm in architectural surfaces.

Driven by the quest for new market niches, this revolutionary tile collection seamlessly integrates mosaic, ceramic, and 3D wall elements into one cohesive system. Designed in an innovative 2" x 2" 1/4 format, it offers endless configurations, making it perfect for a wide range of design projects, especially in compact spaces.

Transitioning effortlessly between flat and 3D textures, and from geometric precision to organic randomness, Squar brings an artistic dimension to every surface. Available in a hand-painted ceramic version, featuring nine standard patterns and limitless custom interpretations, it is more than just a tile collection—it is an artistic performance.

“Squar Collection gives designers a budget-

friendly way to create artistic installations, transitioning from flat to 3D and from square to irregular shapes using a single product.” — ARCHITECTURAL RECORD, USA

Global Recognition & Awards:

2018 | Architectural Record USA recognized the original 4" x 5" engineered marble Squar version as one of the 8 best surfacing products of the year.

2018 | The original Squar was a Best of Year Honoree by Interior Design USA.

2019 | At Pier 17, NYC, Squar won its second Honoree Award, ranking among the top 4 wall covering products at the Interior Design Magazine event during New York City Design Week.

2021 | Red Dot Award Winner – A prestigious recognition for high design quality, awarded only to products that exemplify outstanding innovation.

“The Red Dot is a symbol of design excellence. The international jury awards this prestigious seal only to products that redefine the boundaries of design.”

— Professor Dr. Peter Zec, Founder & CEO of Red Dot

With Squar, architecture transcends its traditional limits—offering designers a limitless canvas where walls become art.



41" - 105 cm

48" 1/2 / 123 cm

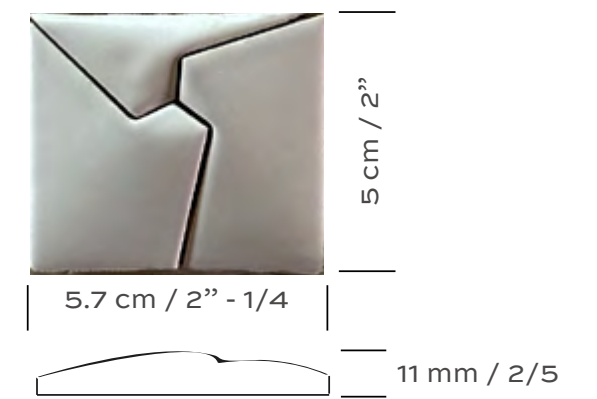
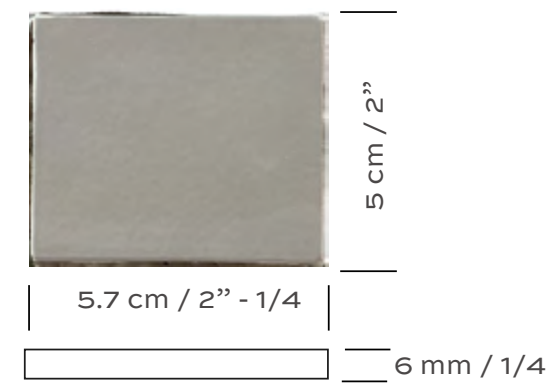



COLOURS



Bianco Matt



Grigio Chiaro



Grigio Scuro

We provide a custom-made colour match as close as possible to your request for final approval before production begins.



Size: 36" x 48" / 91 x 122 cm

Title: "Sparkling #1"
1st of 15 pieces
All different each other.
Colour: white matt

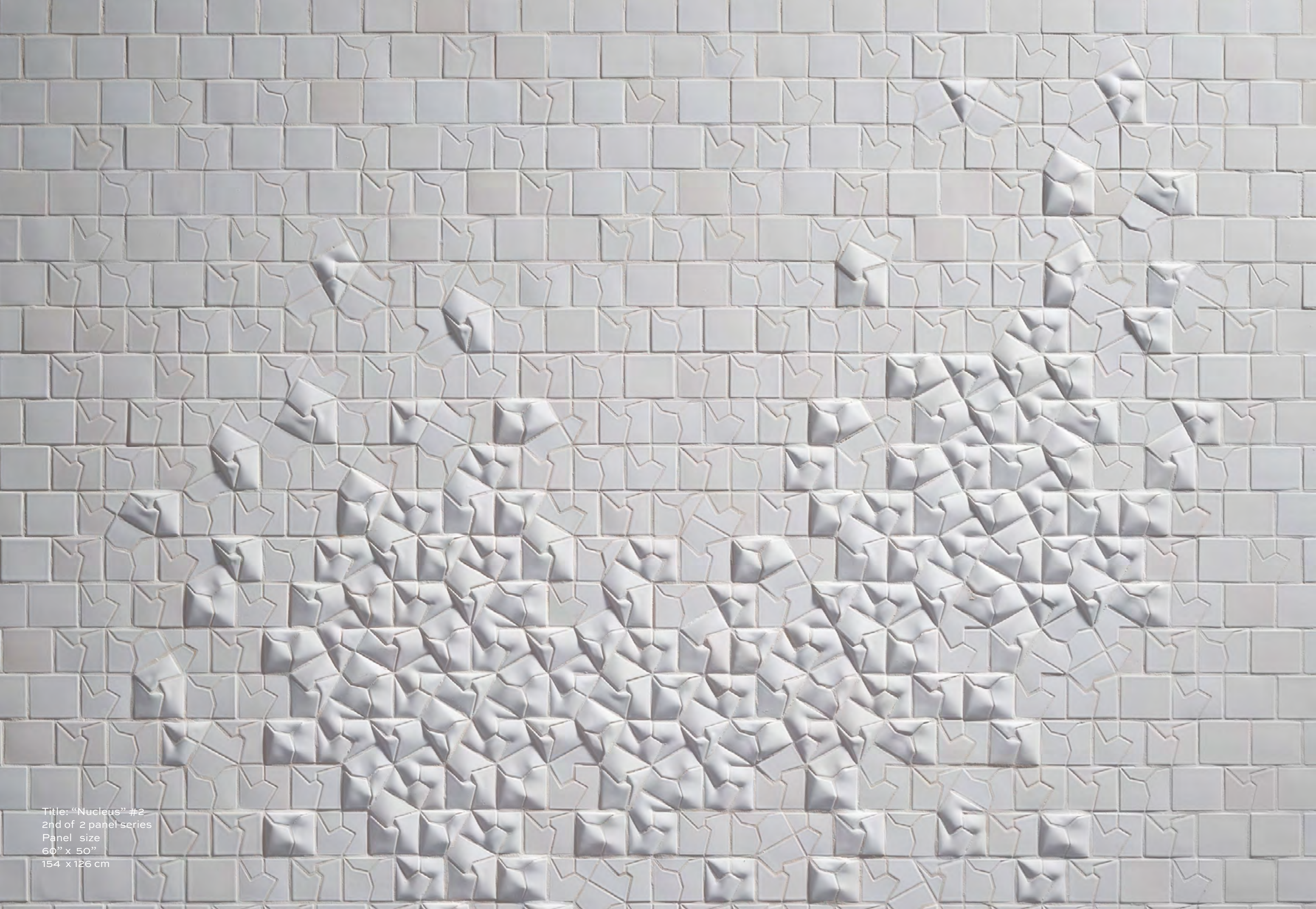

Title: "Nucleus" #2
2nd of 2 panel series
Panel size
60" x 50"
154 x 126 cm



Infinite transitions and combinations can be achieved, influenced by ambient lighting and personal taste, ensuring each project is truly unique. Available for walls in natural stone, flat version only, suitable for both walls and floors, with a high-honed brushed finish. The Squar Collection offers an unparalleled level of personalization, redefining customization with artistic and architectural freedom.

LE PIASTRELLE SEGNATE

HANDMADE ITALIAN TERRACOTTA TILES



reddot winner 2022
best of the best







2023
Luxe USA Magazine RED Award Best Tile Design
 "Le Piastrelle Segnate" for Fornace Brioni - Clè Tile USA
 RED (Residential Excellence in Design)
 Award Winner as 2023 Best Tile Design

“Le Piastrelle Segnate”, designed by Giovanni Barbieri for Fornace Brioni, received the prestigious Red Dot Product Design Best of the Best Award for its groundbreaking design— the highest honor in the competition.

Tiles have always played a defining role in architecture, reflecting the stylistic essence of their respective eras. Le Piastrelle Segnate reinterprets this tradition with a three-dimensional relief structure, creating a striking presence for both walls and floors.

The collection consists of three tile variations, each measuring 20 x 20 cm, distinguished by the density of their reliefs. This thoughtful gradation

not only enhances their aesthetic appeal but also ensures effortless and intuitive installation. The result is a visually dynamic surface with an interplay of light and shadow, achieving an effect that feels entirely custom, despite being composed of only three standard models.

Additionally, the transition from dense relief structures to smoother field tiles, combined with optional accessory elements, allows for a wide range of decorative solutions. This versatility transforms each installation into a unique artistic composition, where texture and form redefine the boundaries of tile design.

(Red Dot Award jury statement)



COLOURS & DIMENSIONS



Sabbia



Cenere

20cm / 8"

20 cm / 8"



Terra

18 mm
3/4



25 mm
1"

INSTALLATION LAY-OUT

Quick random installation obtaining,
almost never repetitive and unique look.

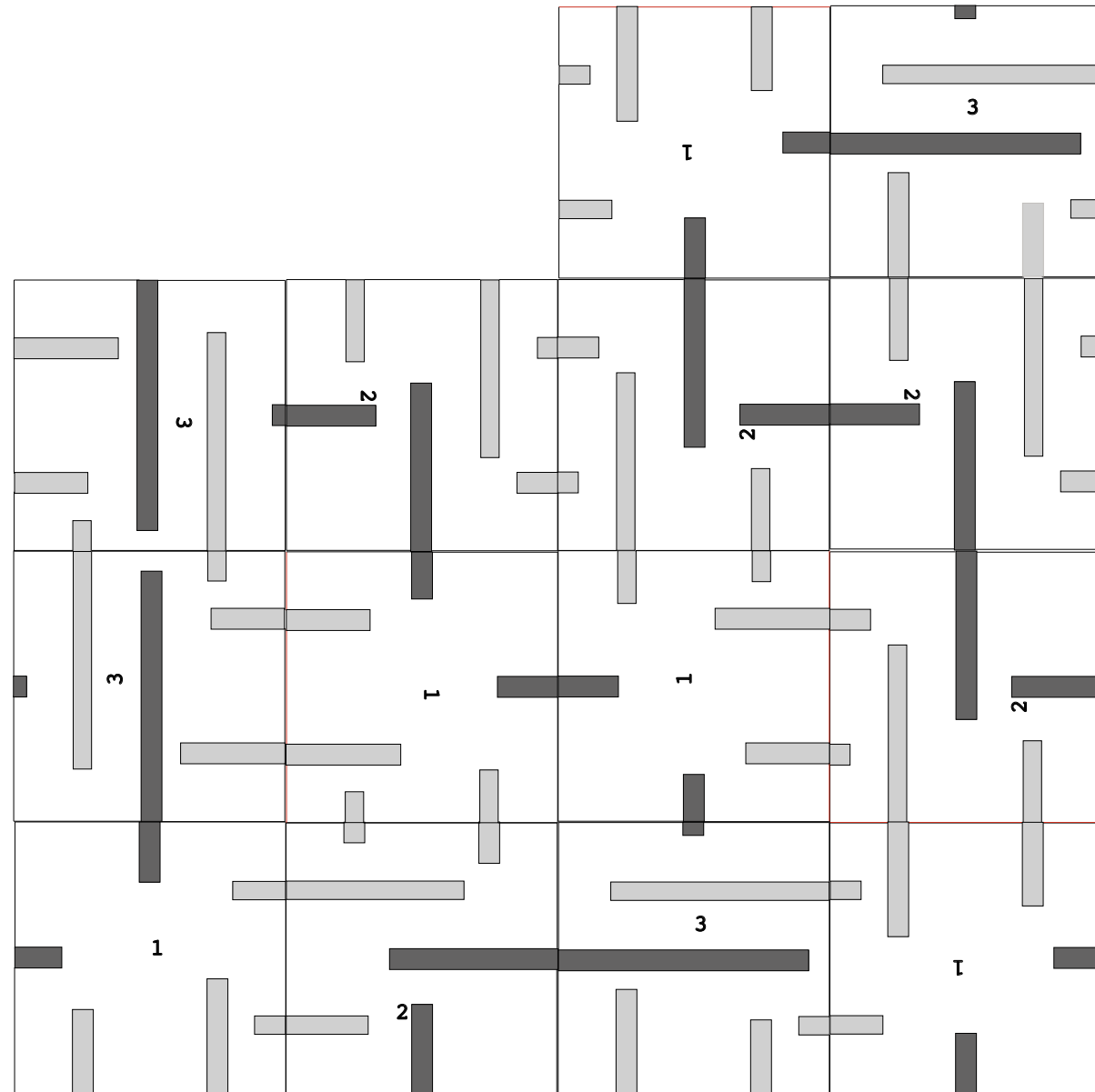

Just simply taking care to match double and single signs tile sides each other. The laying of the first or upper row must be started only on one side or in the middle never from two different positions at the same time on the same.

3 MODELS

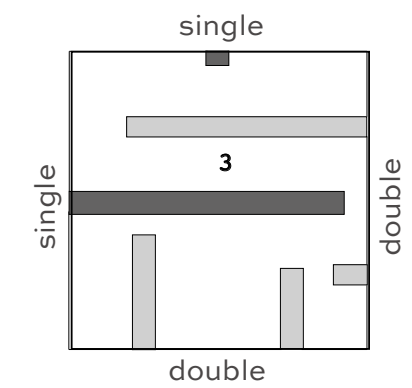
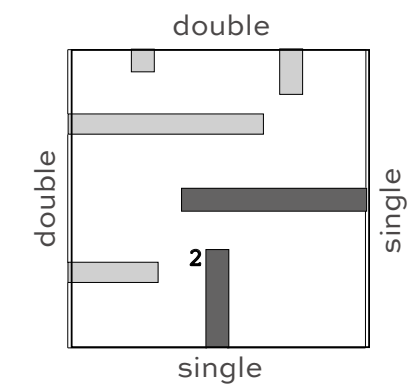
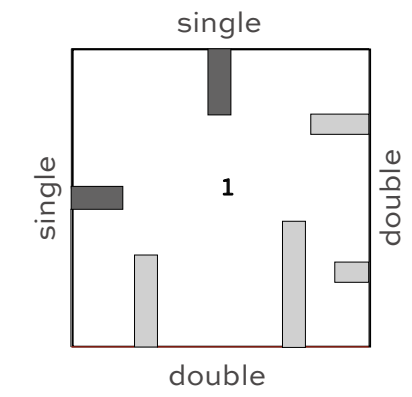



“The decorative tiles becomes the part
in movement of an empty, static wall “



"A wall covering must always appear to be in constant motion, never static or repetitive, because this is our contemporaneity."



STRALLERI

THE POETRY OF A MARBLE MOSAIC
WITH A REBELLIOUS SOUL

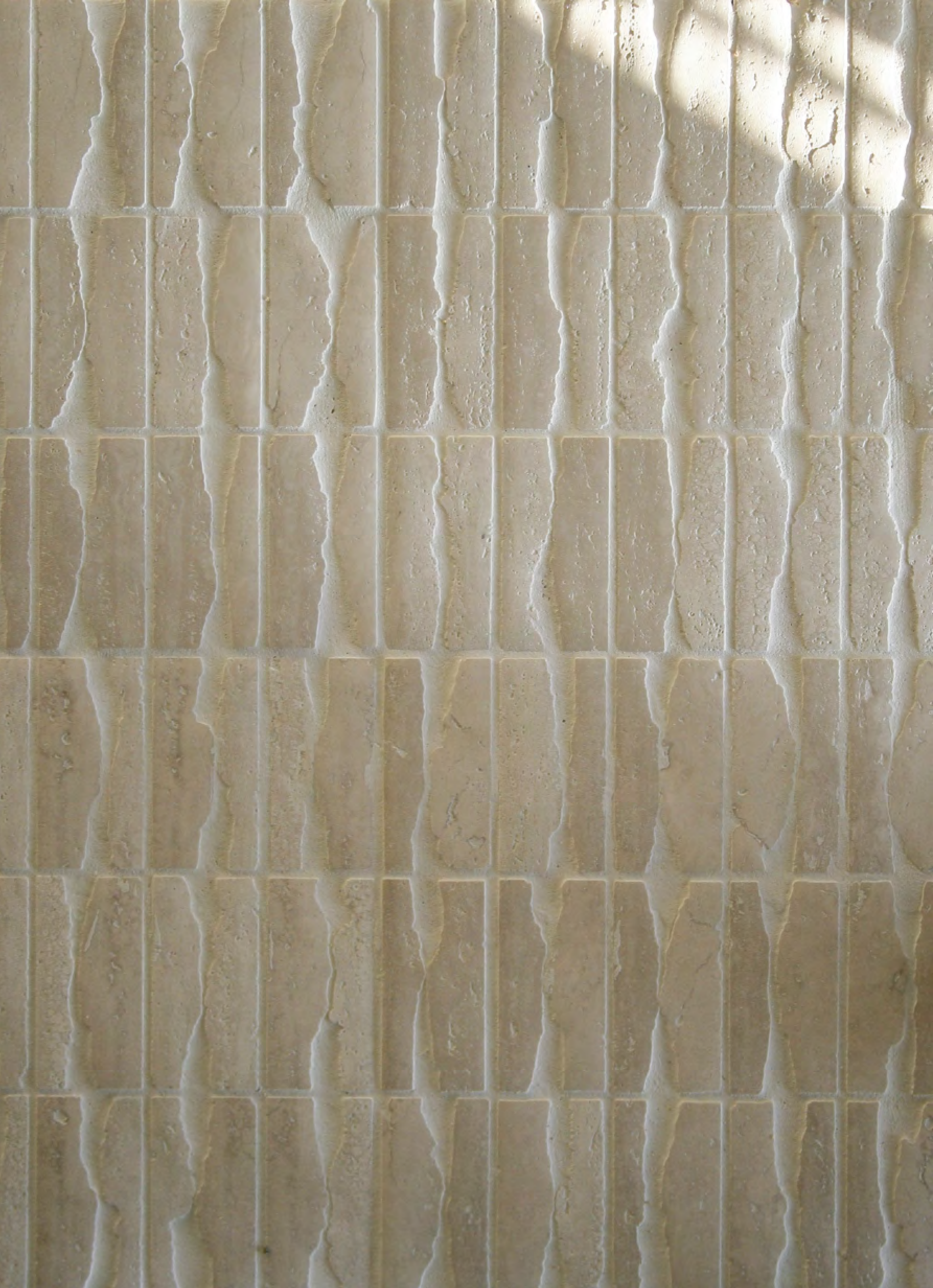

Giovanni Barbieri presents his innovative collection for wall and floor coverings with a unique charm.

Schiavon, Vicenza - November 2024 – Giovanni Barbieri rediscovers the beauty of marble mosaics, rewriting their aesthetic canons with a new artistic language. Irregular shapes and delicate shades combine with artisan mastery in the Stralleri collection, giving life to decorative solutions with a high material impact.

The tiles in Carrara Marble or Travertino Classico are characterized by three regularly cut sides and one side that, split manually, creates “movement” in the composition, giving it a strong expressiveness. This is the heart of the collection, capable of enhancing the singular and rebellious spirit intrinsic in natural stone: the split creates different sides, giving each tile its own identity, which also changes depending on the type of marble used.

A “dynamic” and never repetitive mosaic, Stralleri thus reveals a poetic essence and allows for vertical

or horizontal installation of the split side, so as to give, in combination with the joints, more emphasis to the “wild” or regular soul of the decoration.

The uniqueness of the naturally split marble marries with the flat surface of the tile, combining beauty and ease of maintenance.

Designed for walls and floors, even high traffic, this new collection by Giovanni Barbieri is designed to enhance various residential and commercial environments that wish to combine the exclusivity of an innovative and elegant design with the naturalness of the raw material.

The Stralleri collection is available in tiles in the 12.6 x 6 cm and 6 x 6 cm formats, which can be combined with each other. The mosaic is mounted on a mesh with a satin finish and can also be used as a decorative border. Numerous stucco colours are available to delicately underline or accentuate the effect of the naturally split sides, creating a personalized play of colours



COLOURS

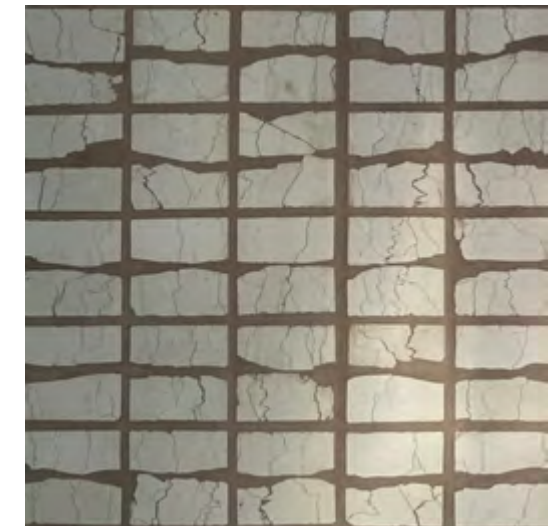
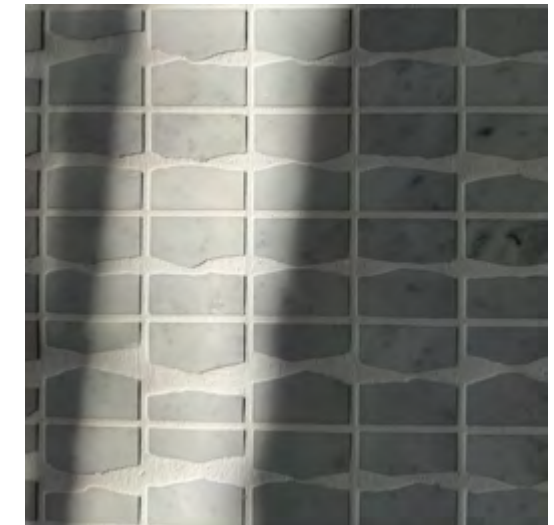

REGOLI
BIANCO CARRARA MARBLE TILES



London UK Event at
Nobu Hotel Portman Square
22nd October 2021

REGOLI Collection
has been selected as finalists at SBID
(The Society of British International Interior Design)
London International Design Awards.



New York City City Event at
Cipriani South
21st September 2021

REGOLI Collection
has been selected as finalists
at Hospitality Design Awards



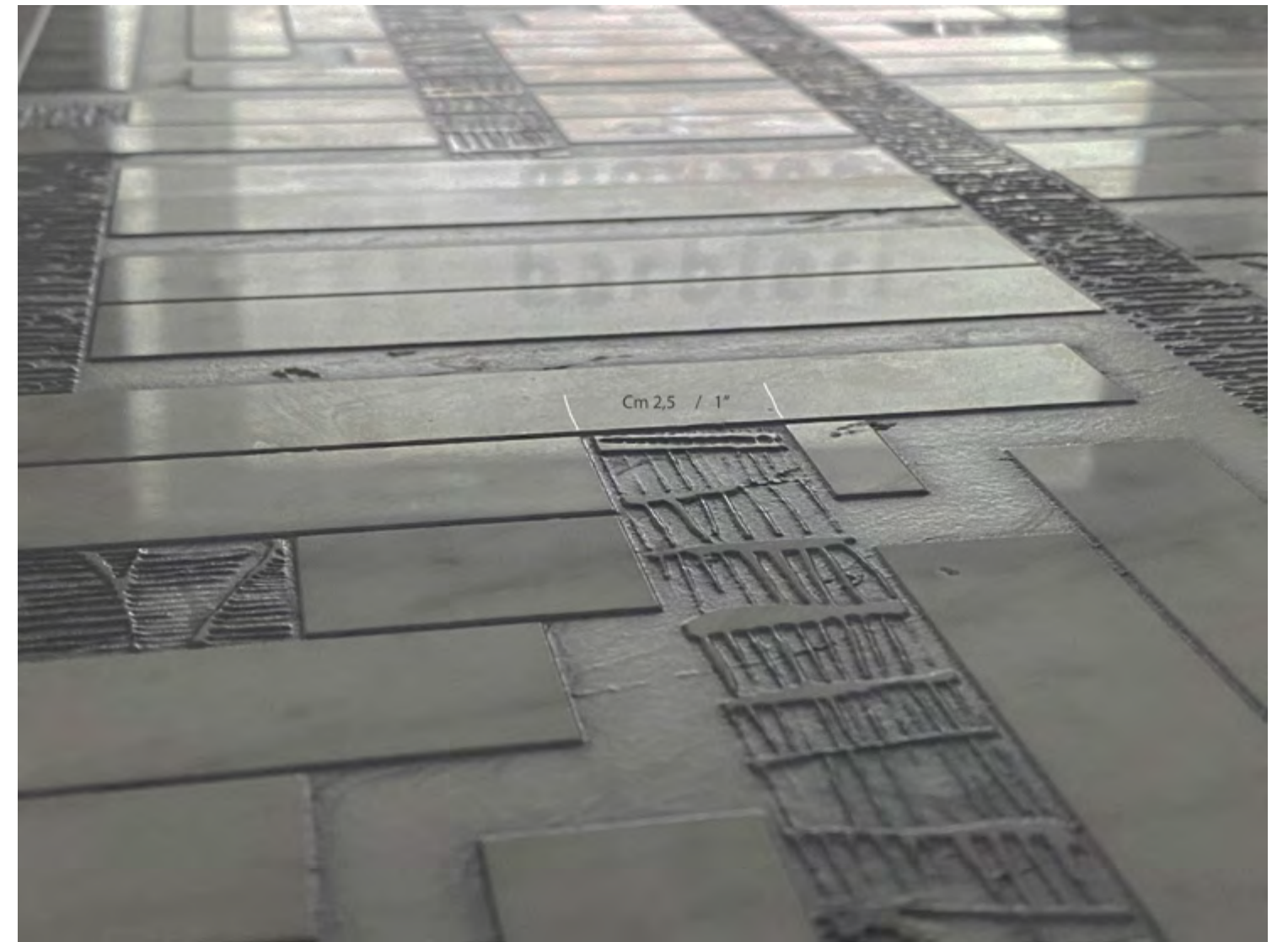

The Regoli Collection by Giovanni Barbieri offers a sophisticated yet simple approach to the herringbone pattern, allowing for effortless creation of diverse designs. Crafted using the artisanal “Acquaforse” technique on Bianco Carrara marble tiles, it brings a contemporary elegance reminiscent of Carlo Scarpa’s concrete structures in Treviso. Blending tradition with innovation, Regoli opens new possibilities for creativity and refined aesthetics in modern design.



LINEAR MODEL



30,5 cm / 12"

30,5 cm / 12"

HERRINGBONE MODEL

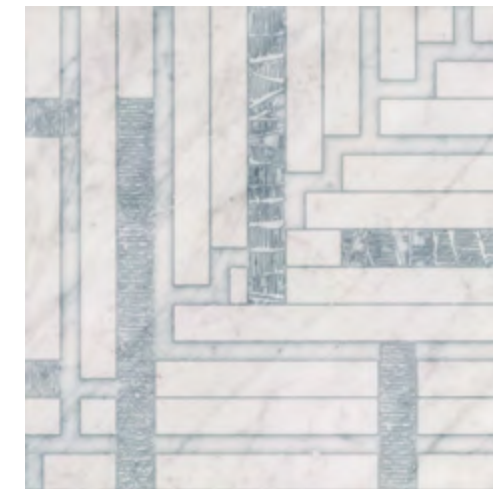
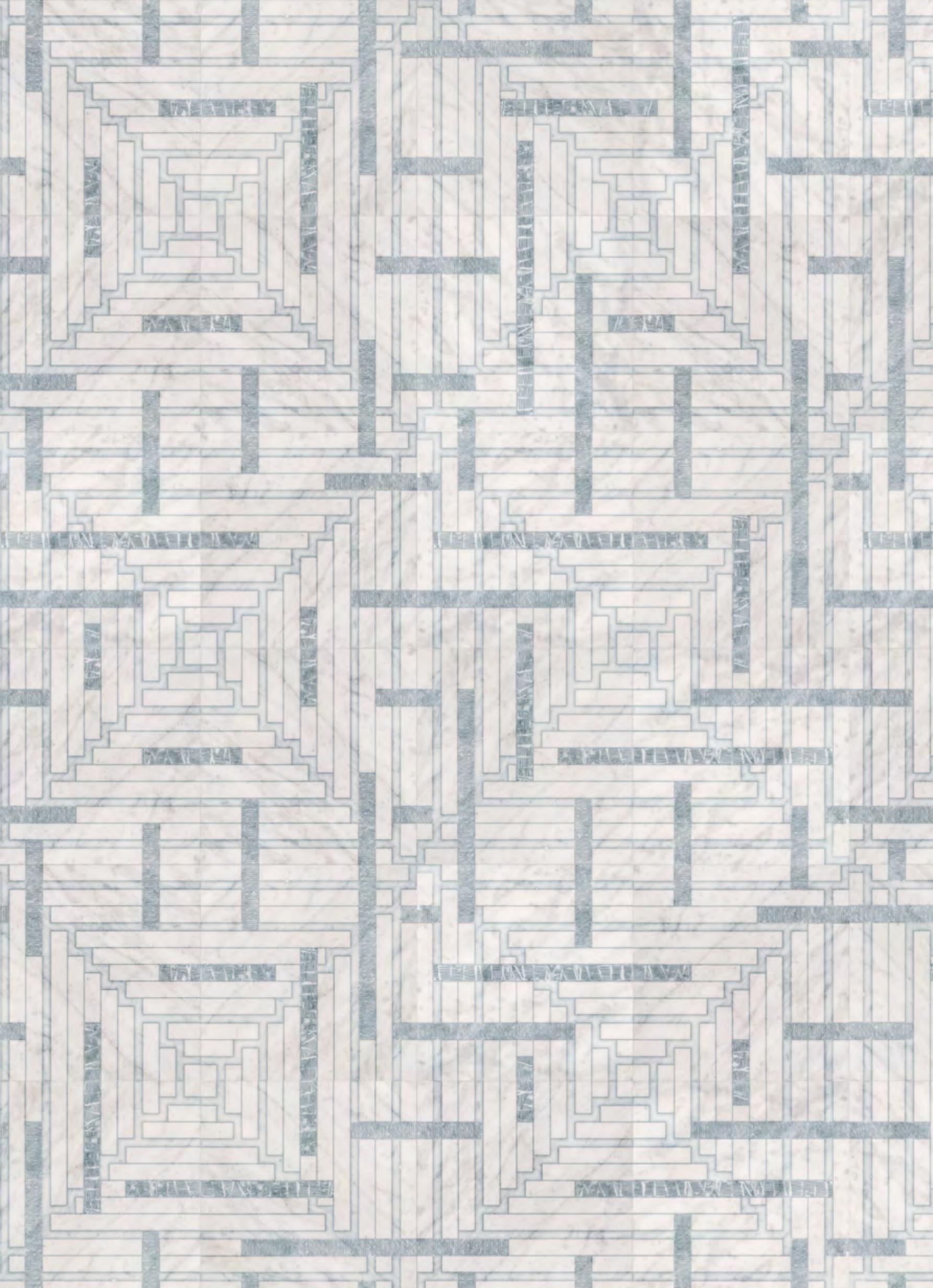

30,5 cm / 12"

30,5 cm / 12"

CONTEMPORAINE
A NEW MOSAICS



Carrara Marble, 1" 1/2 x 1" 1/2
(3,7 x 3,7 cm)

The evolution of our exclusive production system has elevated the quality of our creations to a new level. We are thrilled to introduce a contemporary mosaic featuring a meticulously refined finish and consistent shapes. Each piece showcases intricate details and subtle differences, creating an aesthetic that is both visually striking and captivating to the touch. The interplay of honed reflections enhances its modern, minimal, and sophisticated design, resulting in a unique and timeless masterpiece.

SOLID MARBLE MOSAIC

A NEW CONCEPT FOR NATURAL SPLIT STONE



The Solid Marble Mosaic seamlessly blends traditional and contemporary elements, offering a fresh aesthetic for natural stone walls. Featuring a 2" x 2" (5x5 cm) cross-section with both raw cut and naturally split surfaces, this innovative 3/4" (1.7 cm) thick mosaic redefines wall design. Meticulously crafted, these pieces bring timeless elegance and sophistication to any space. 100% natural classic light travertine.



2" (5 cm) x 3/4" (1.8 cm) Thickness
100% Natural Classic Light Travertine



The SPA at The Luxury Collection Bristol
5-Star Hotel in Warsaw, Poland.

DEPTHILE
SOFT THREE-DIMENSIONAL EFFECT



The Depthile Collection is crafted from Italian marble tiles, featuring a mix of straight and cushion-edged tiles on each piece with a high-honed surface. The unique shading edge effect is enhanced by natural light, ensuring effortless installation and easy maintenance.

As the first natural stone tile to offer a soft three-dimensional effect while maintaining a flat surface, Depthile delivers a truly distinctive look, perfect for both floors and walls. The cushion edge provides a smooth and comfortable finish, making it an ideal choice for bathroom and kitchen wall coverings.

Available sizes:

2" x 12" x 3/8" (5 x 30.5 x 1 cm)

3" x 18" x 3/8" (7.5 x 45.7 x 1 cm)

Material: Carrara Marble Tiles

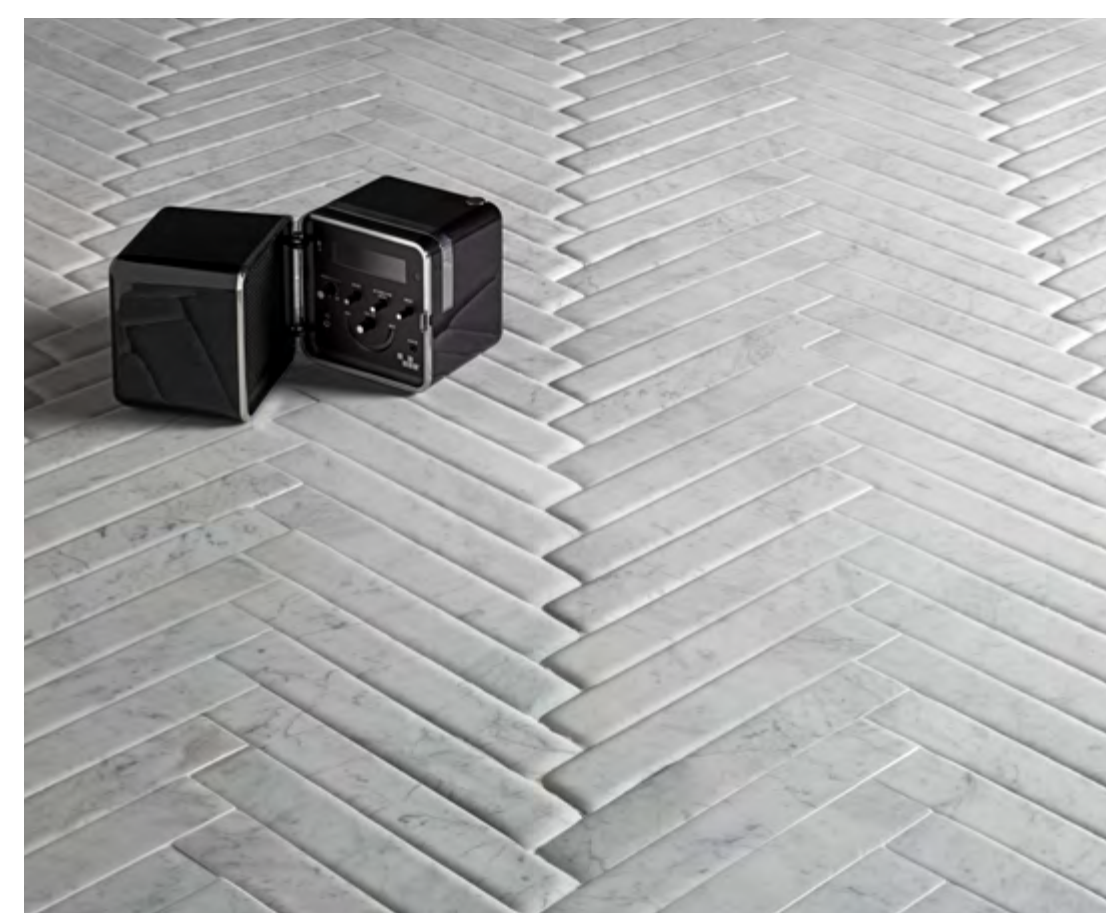



Architizer
A+AWARDS
WINNER
2021

Depthile Carrara Marble Tiles have been installed in an INTERIOR DESIGN USA Best of Year Award-winning project in the Bath category by Snorre Stinessen.

Additionally, Aurora Lodge by Snorre Stinessen has been recognized as an Architizer A+Awards Winner in the Residential category.



Aurora lodge | Nord-lenangen, Norway
designed by Snorre Stinessen
Featuring 2" x 12" x 3/8" (5 x 30.5 X 1 cm) carrara
marble tiles.



THE TIMEWORN MOSAIC
HONORING AND PRESERVING THE HISTORICAL
ESSENCE OF NATURAL STONE MOSAICS



“A PRIMITIVE BEAUTY “

“For myself, the Timeworn mosaic in my home is more than just a decor piece – it embodies the essence of existence. Living with this 100% natural stone, handmade in Italy creation, I am reminded daily of the untouched beauty of our history and nature.

Each hand-cut piece, deliberately unique, highlights the sacredness of imperfection.

The manual installation on mesh, with minimal joints, brings a sense of primordial authenticity that stands out in today’s world of artificiality”.

Introducing an innovative surface finishing pattern that redefines elegance and sustainability in natural stone mosaic. As an evolution of Giovanni Barbieri’s pioneering 1999 invention, this advanced technology creates a distinctive aesthetic by delicately wearing out tile borders, resulting in a semi-opaque, naturally wavy surface.

Beyond enhancing the beauty of marble, this process preserves its historical essence. By selectively “consuming” the softer elements of the marble composition, it allows for subsequent polishing that perfectly matches the quality of original historical floors.

What sets this technique apart is its unwavering commitment to sustainability, utilizing only ecological abrasives throughout the process. This method not only ensures exceptional aesthetics in antiqued natural stone tiles but also offers ease of maintenance and long-term durability.

To optimize performance across various settings, applying an oil water-repellent protection is recommended, enhancing longevity while preserving the surface’s pristine appearance over time. Even in the case of deep scratches, restoration is easily achievable using specialized electrical tools commonly employed by marble artisans. The meticulous hand-finishing process with fine glass paper ensures a seamless blend with the existing texture and aesthetic.

With intricate waves merging effortlessly with current grooves, this finishing technique offers a cohesive, harmonious appearance that balances functionality and beauty. Experience the fusion of artistry and sustainability with this exceptional natural stone surface.

MATERIALS



Bianco Antico (upper)
Carrara (lower)

COLOURS

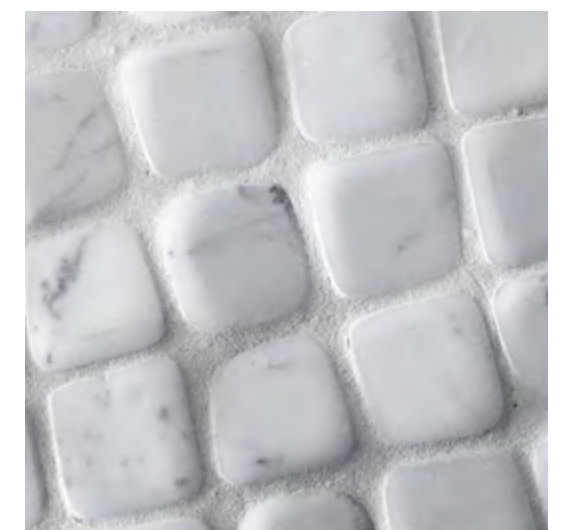
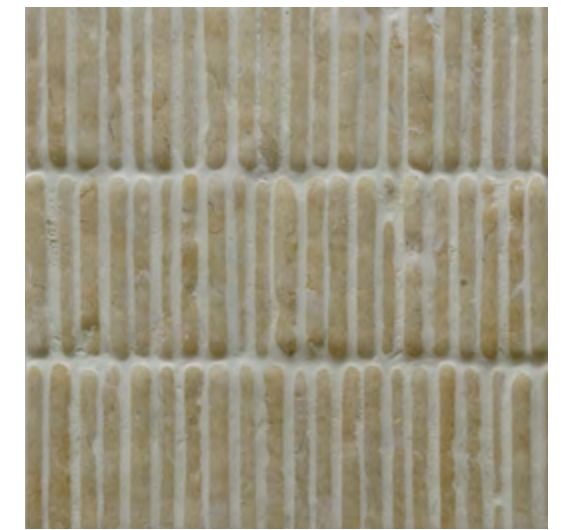
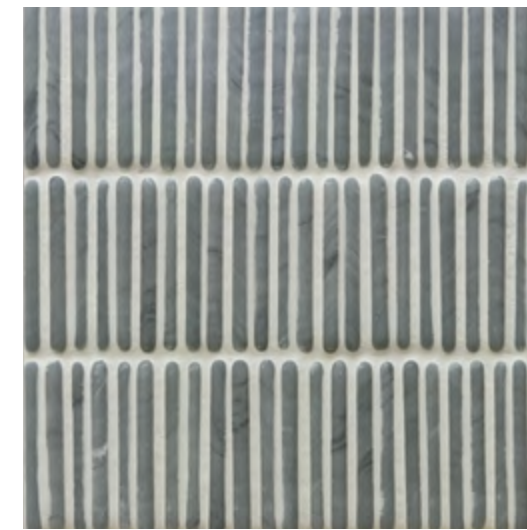
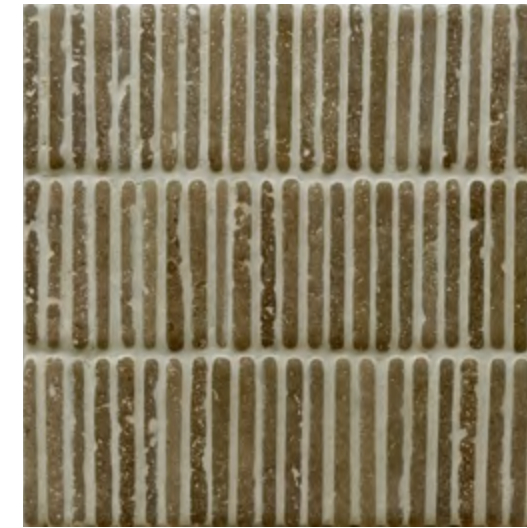

From left to right, up and down:
Noce Travertine, Dusk Travertine,
Bardiglio Imperiale, Jerusalem Gold,
Black Marble, Calacatta

THE SAME TWO MODELS CREATE
TWO DIFFERENT PATTERNS



The herringbone

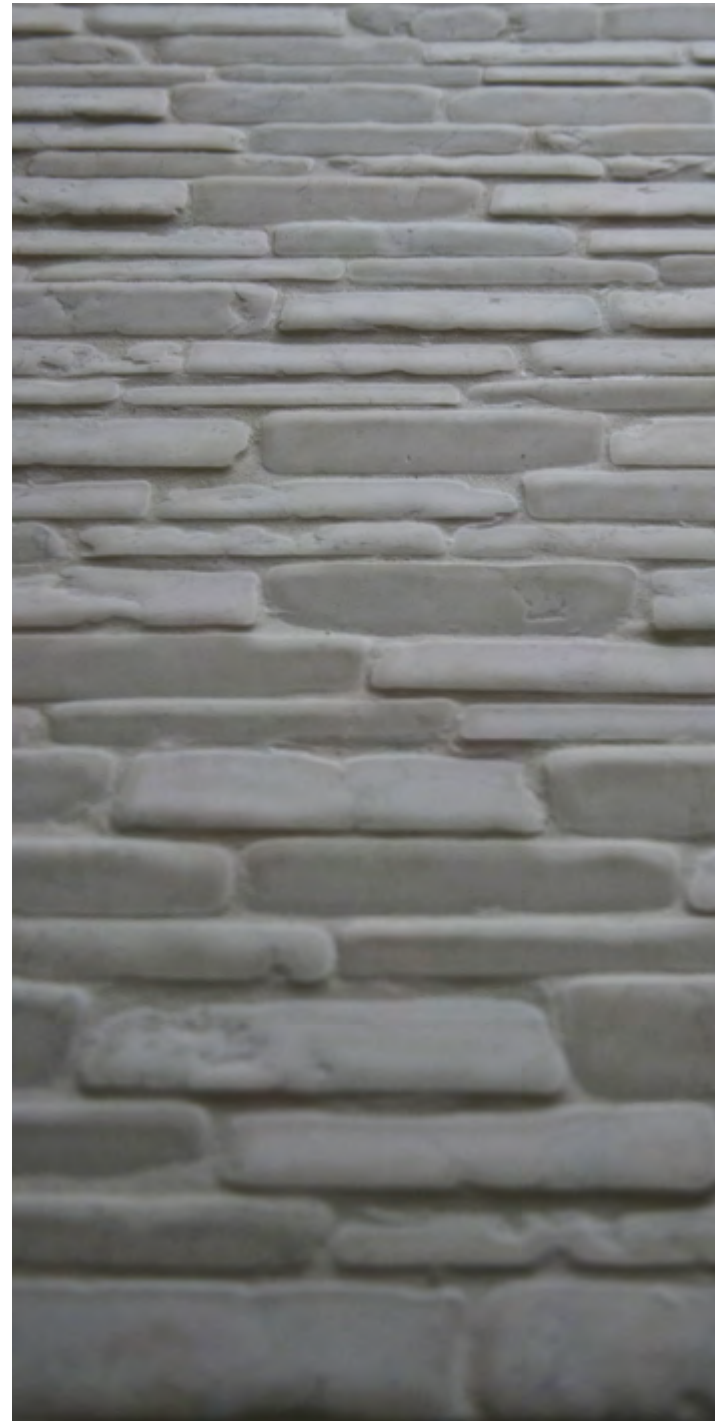

Free lengths

THE HERRINGBONE

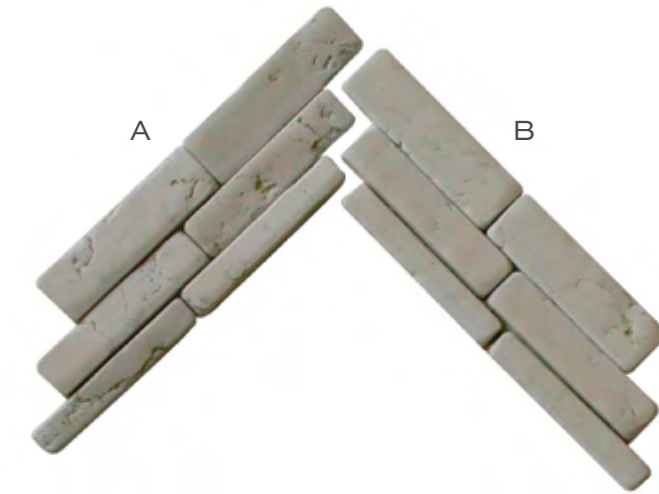

BIANCO ANTICO italian marble

Size 1", 1" 1/2 and 2" x 6" lengths
On net size 0,33 sq. Ft, total thickness 3/8 - 1/4

2 Models create two patterns.
Carrara and bianco antico italian marble.



BIANCO ANTICO VS CARRARA



Top Line : Bianco Antico and Carrara
 2" x 4" (5 x 10 cm) staggered mesh mounted
 middle and bottom Line: Bianco Antico 2" x 2" (5 x 5 cm)
 mesh mounted thickness 3/8 on 1,0 Sq. ft. net



THE FLAT VERSION TIMEWORN MOSAICS



Bianco Antico 2" x 2" (5 x 5 cm)

The Timeworn FLAT version Mosaic having less structured textures than before, much more harmoniously consumption high honed surface finishing, suitable and comfortable for floor with new patterns also, giving a much more sophisticated and genuine look.



BIANCO ANTICO ITALIAN MARBLE
THE MATCHSTICKS



Bianco Antico Italian Marble 1/2 x 4" x 3/8" (1,2 x 10 x 1 cm) covering 1.0 sq. ft. net.



Walnut (NOCE) Travertine
5/8 x 5" x 3/8 (1,6 x 12,5 x 1 cm) On 0,82 Sq. Ft. net.

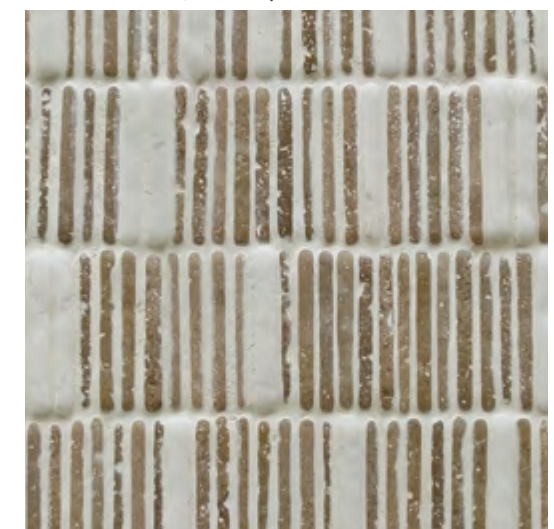

Bianco Antico Italian Marble with Walnut (NOCE) Travertine inlays
1/2 x 4" x 3/8 (1,2 x 10 x 1 cm) on 1,0 Sq. Ft. net
Walnut (NOCE) Travertine WITH Bianco Antico Italian Marble inlays

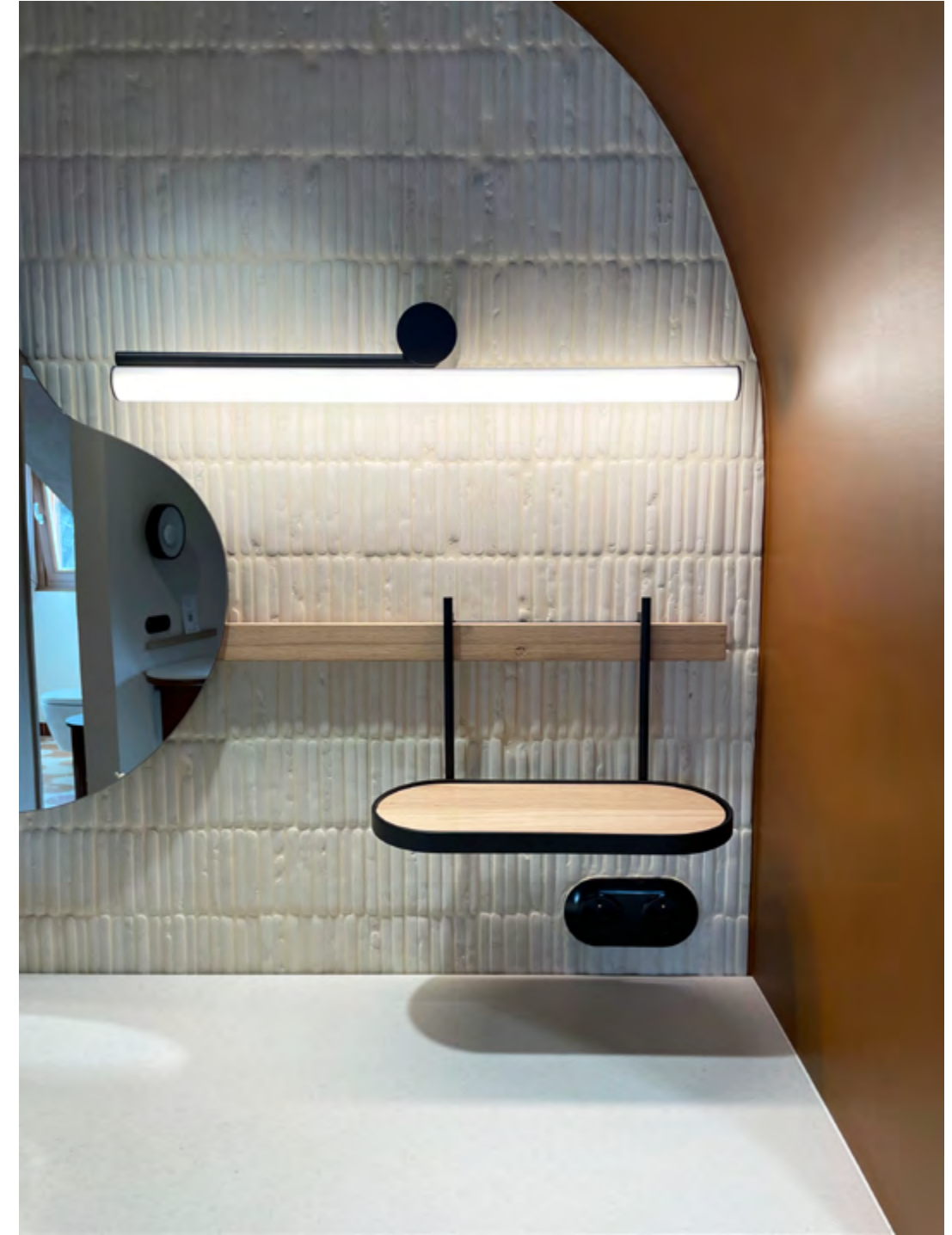

Bianco Antico Marble 1/2 x 4" x 3/8"
(1.2 x 10 x 1 cm) covering 1.0 sq. ft. net.
Hotel Restaurant Frankenburg, La Vallette, France
Project by @parisbrooklyn_design
Photo by @el_winter_photography

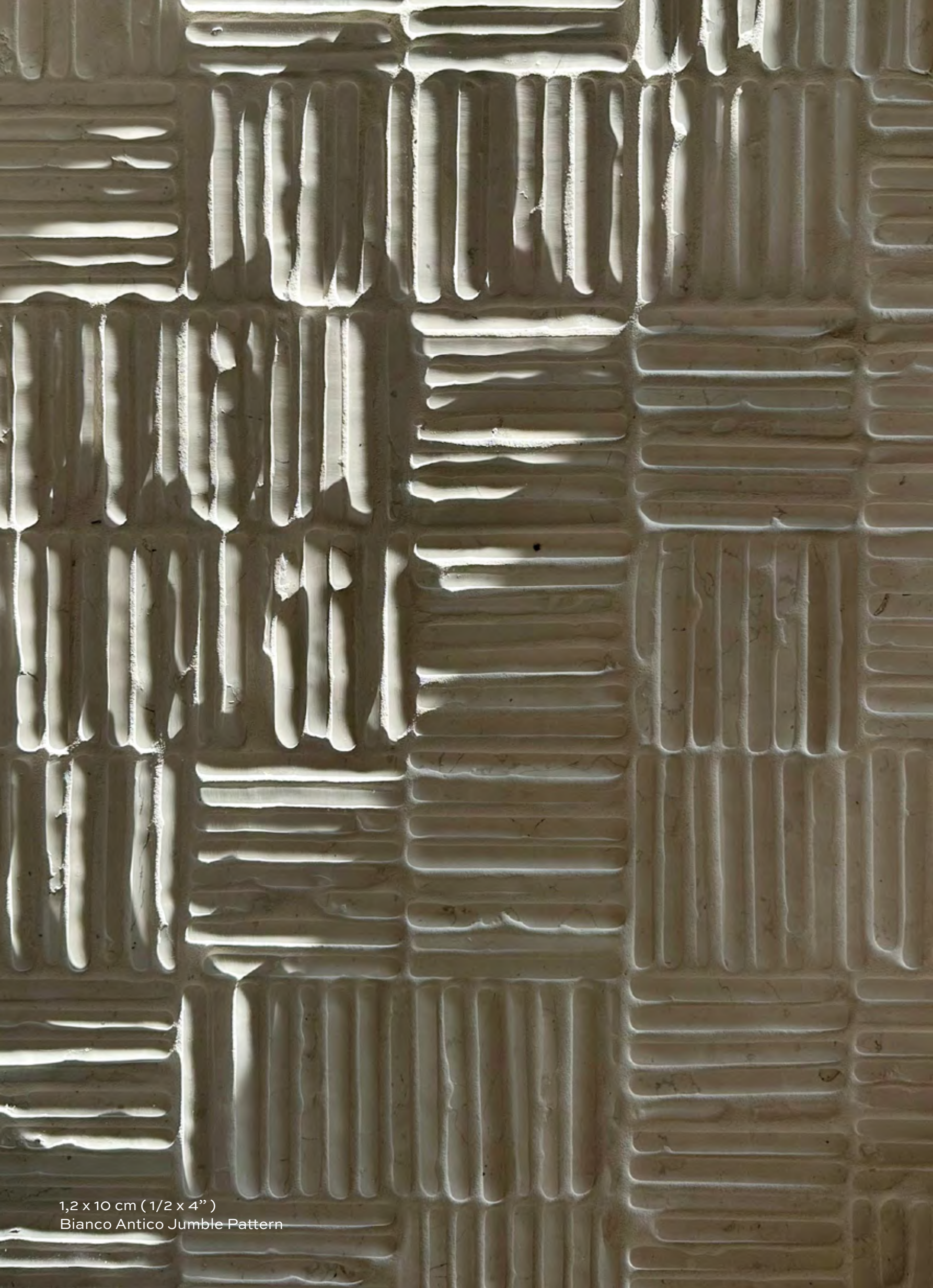

1,2 x 10 cm (1/2 x 4")
Bianco Antico Jumble Pattern

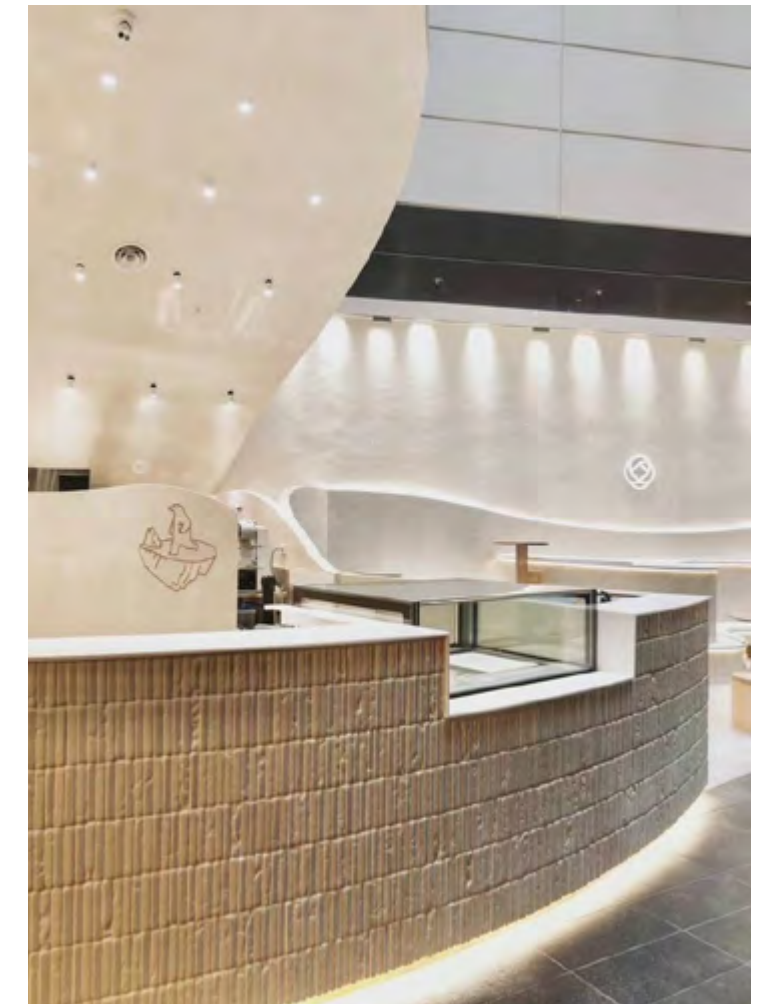

Bianco Antico 12,5 x 15 cm (1" x 6") mesh mounted.

Arctic White, a chic bubble tea shop at the Regent Place Shopping Centre, Sydney, Australia.

Project: <http://dconstructionoffice.com/>



Bianco Antico italian marble
2" x hand-cut x 3/8
on 0,93 Sq. Ft. net.



CARRARA

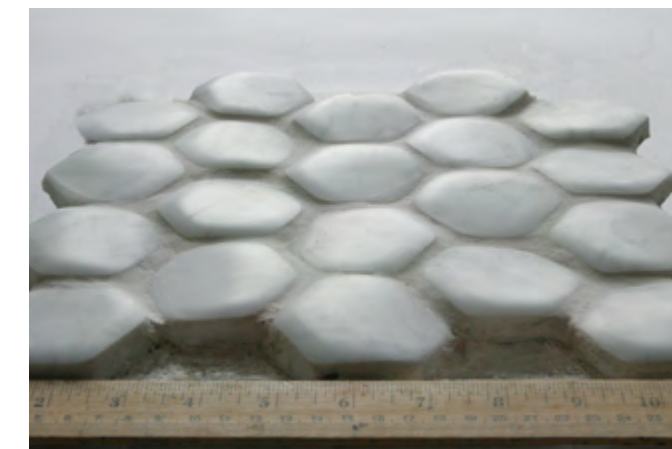

Carrara Hexagon 1" 3/8 (3,5 cm) 0,753
sq. ft. net

On left page : Bianco Antico



Bianco Antico 2" x 4" / 5 x 10 cm
courtesy of Marilyn Aenchbacher - IDAHO - USA



Carrara
2" x 4" / 5 x 10 cm



Bianco antico (left), Carrara (right)
3" (7.5 cm) x short free lengths, x 3/8"
on 0.97 sq. ft. net. interlock.



JERUSALEM GOLD



above: Jerusalem gold pattern: single line every 2" (5 cm)
below: Jerusalem gold: randomly mixed 2" (5 cm)



CUSTOM MADE

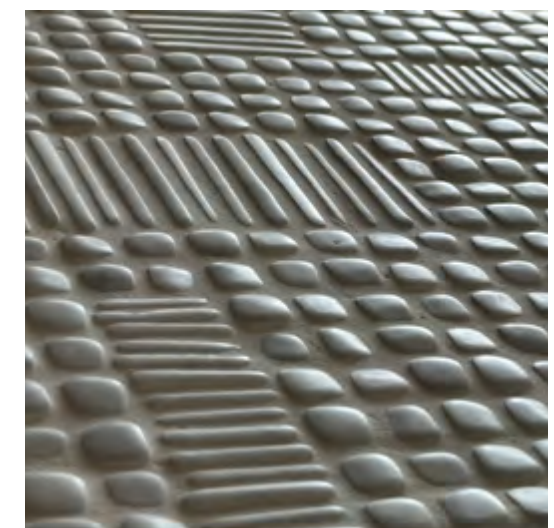
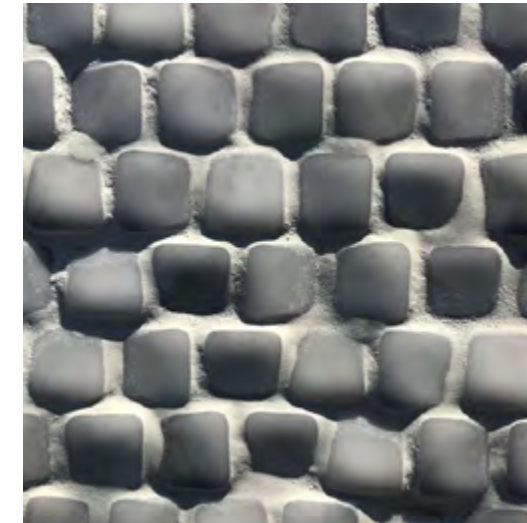

From left to right, up and down:
1/2 x 4" Jumble pattern, 2" x free lengths Tuscan
Colourways, 3/4 x 3/4 (2 x 2 cm) staggered,
Pattern #11, Pattern #13

CUSTOM MADE



Shading from dark grey to white using 9 different kind of italian marble.
size 3/4 x 1" to 1" 3/4 (2 x 2,5 to 4,5 cm)
Courtesy of Mr. Pener, Breckenridge, Colorado.



Overall Winner at International SBID (The Society of British International Interior Design) London Design Awards 2020.

The Fine Lines by Barbieri

“Selected from the Flooring & Floorcoverings category, The Fine Lines strikes the balance between crafting a handmade, artisan tile collection and achieving premium art performance.”



New York City Boutique Design International Product Design competition.

“The Fine Lines Terrazzo by Barbieri has been selected as a WINNER in the Hard Surface Flooring category for the 2020 BD Product Design Competition.

Presented by Boutique Design magazine and BDNY, the competition celebrates designers and manufacturers of products that demonstrate aesthetic progress, functionality, and above all, innovation”.



New York City City Event at Cipriani South 21st September 2021

The Fine Lines Terrazzo Collection has been the Winner at Hospitality Design Awards #HDAwards2021.

THE FINE LINES

ITALIAN TERRAZZO CUSTOM MADE TILE



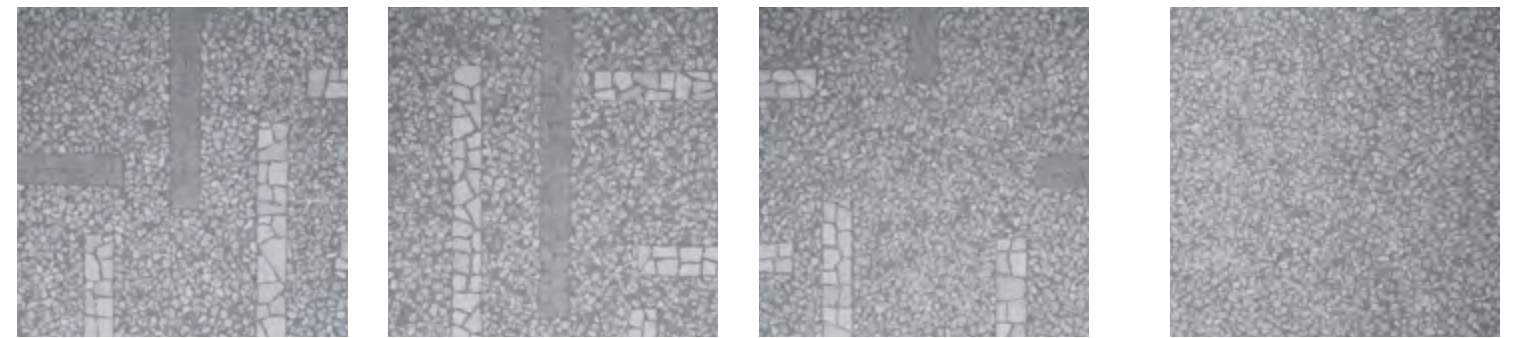
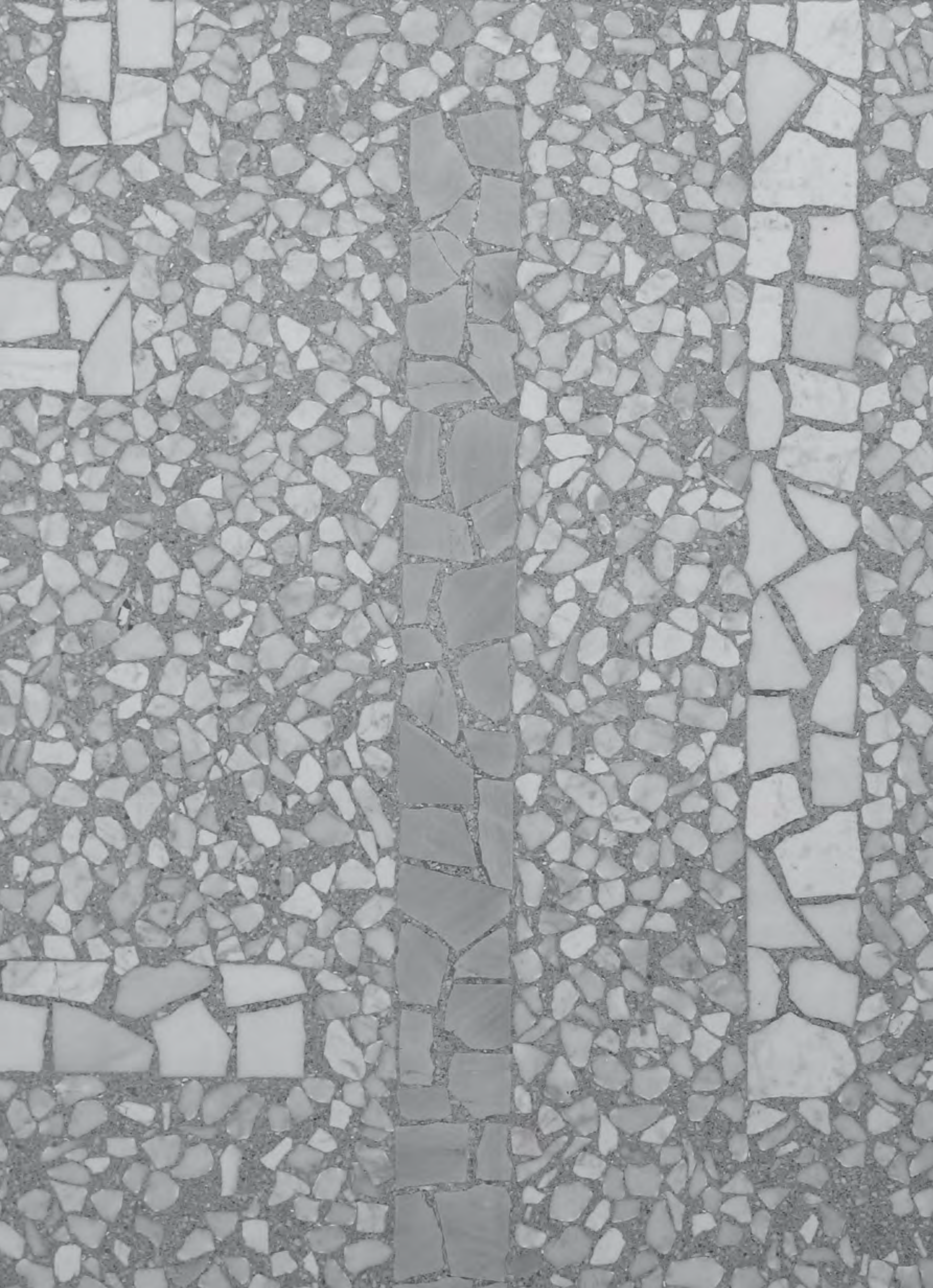

Founded in the Veneto Region, in Vicenza—where Terrazzo alla Veneziana originates—Laboratorio Morsetto has epitomized excellence in custom-made Terrazzo for over 100 years. Renowned for executing numerous projects by Carlo Scarpa and, more recently, some of the most prestigious Valentino stores, the company remains dedicated to preserving this invaluable technique. Offering unparalleled craftsmanship, Laboratorio Morsetto caters to architects, designers, and homeowners seeking to incorporate a piece of Venetian history into their creations. Suitable for both commercial and residential use, their expertise extends beyond flooring to include large-scale elements such as tables, stairs, and support surfaces, all seamlessly coordinated with the floor.

Proudly introducing The Fine Lines Collection, this innovative design features a purely random arrangement of three tile patterns, harmonizing with hand-inlaid Palladiana lines to achieve an extraordinarily unique aesthetic. Each inlaid line, crafted with exceptional precision exclusive to Laboratorio Morsetto, varies subtly in length, producing a “patternless effect” reminiscent

of a work of art. Unlike standard slab supply, Laboratorio Morsetto also specializes in on-site fabrication for a truly bespoke result.

Designed by Giovanni Barbieri, this collection embodies a simple yet essential principle: an easy-to-install, intricate, and unique aesthetic with no repetitive patterns.

The Fine Lines Collection Specifications:

- Tile dimensions per model: 23 5/8” x 23 5/8” x 3/4” (60.0 x 60.0 x 2 cm)
- Total coverage of three combined models: 11.61 sq. ft. (1.08 sq. m.)
- Custom colorways available, incorporating natural stone, metal, or terracotta inlays
- Surface finish options: Standard High Honed, with Polished or Timeworn available upon request

For seamless integration, joints can be avoided by opting for on-site installation instead of pre-cut tiles or slabs. Color combinations can be fully customized to align with individual preferences.

THE MOSAICO
EXCEPTIONAL NATURAL STONE SURFACE



Introducing a groundbreaking surface finishing technique that redefines elegance and sustainability in natural stone mosaics.

Evolving from Giovanni Barbieri's pioneering 2011 invention of the Timeworn Mosaic, this advanced technology delicately wears away the surface of exceptionally small (1/2 inch) tesserae, creating a semi-matte, naturally wavy texture. This process not only enhances the visual beauty of marble but also preserves its historical essence—both aesthetically and to the touch.

By selectively eroding the softer elements of the marble's composition, the technique allows for subsequent polishing that seamlessly matches the quality of original historical floors.

What truly sets this innovation apart is its commitment to sustainability—executed entirely with eco-friendly abrasives.

For those seeking exceptional care, low-maintenance upkeep, and a refined distressed finish, this surface offers an unparalleled blend of practicality and timeless beauty.

Experience the perfect fusion of artistry and sustainability with this revolutionary natural stone finish.

(Left) 1/2 x 1/2 x 3/8 (1,2 x 1,2 x 1 cm) natural stone chips on mosaic sheets 6" x 12" (15 x 30,5 cm) on any custom made design/dimensions.

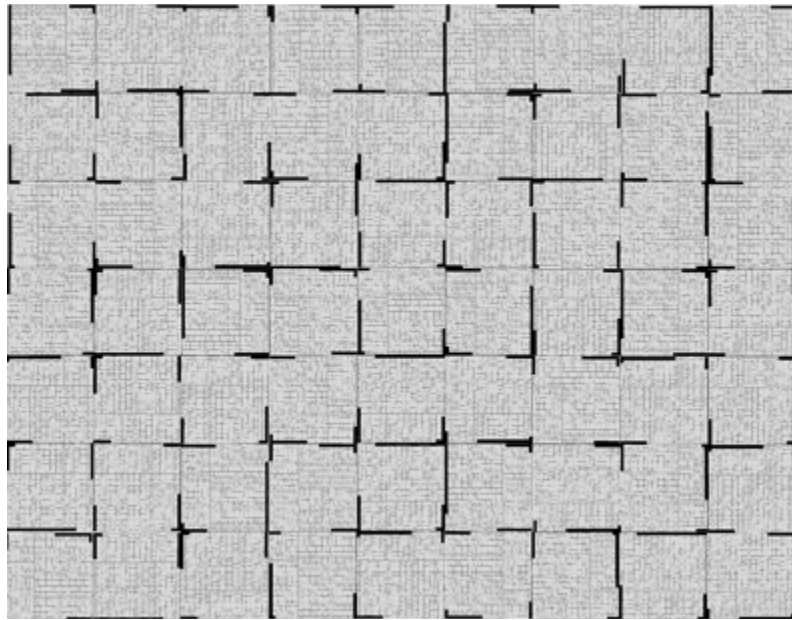

(Left)
 Bianco Antico + Nero Marquinia
 tile size: 12" x 12" (30.5 x 30.5 cm) on net.
 Total thickness: 3/8" (1.0 cm)

(Right)
 Bianco Antico + Nero Marquinia
 panel size: 18" x 38" (45.7 x 96.5 cm) on
 aluminium honeycomb. Total thickness: 1" (2.5 cm)

CUSTOM MADE SERVICES
BASED ON OUR ARTWORK

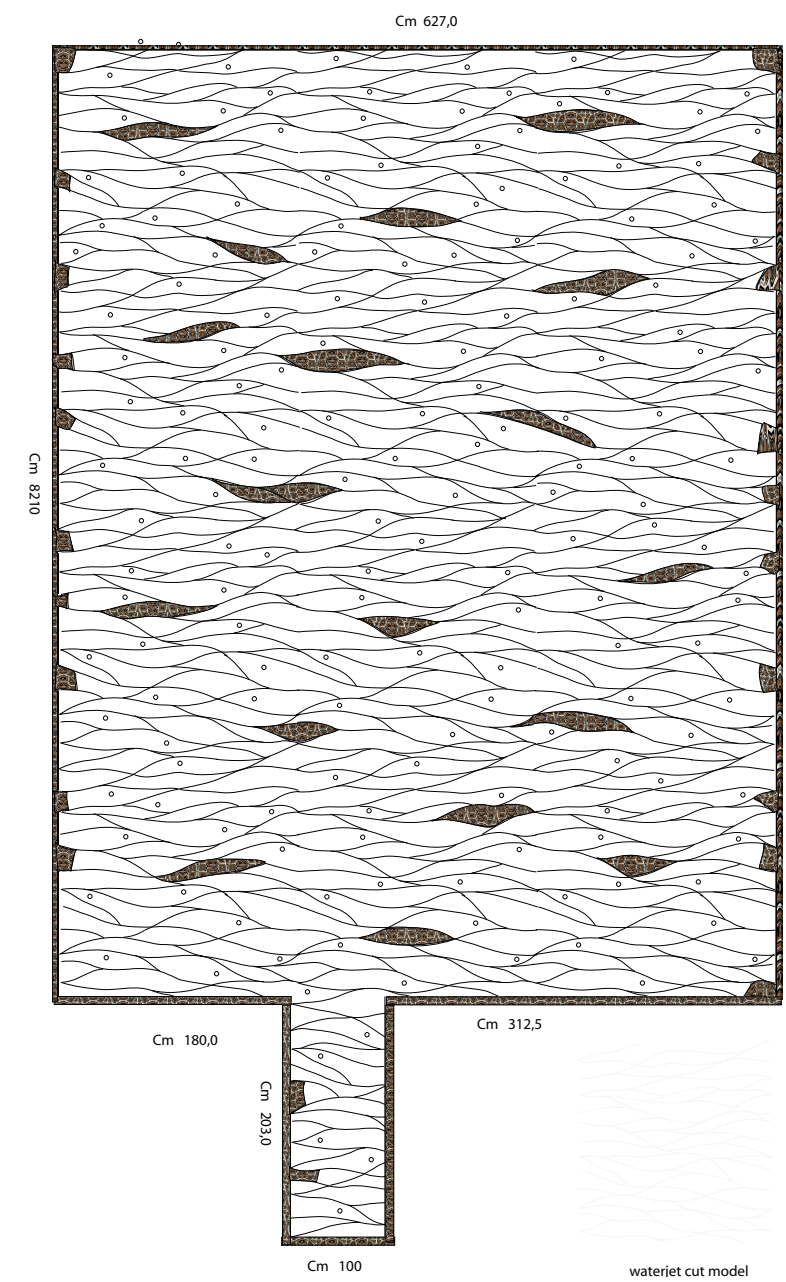
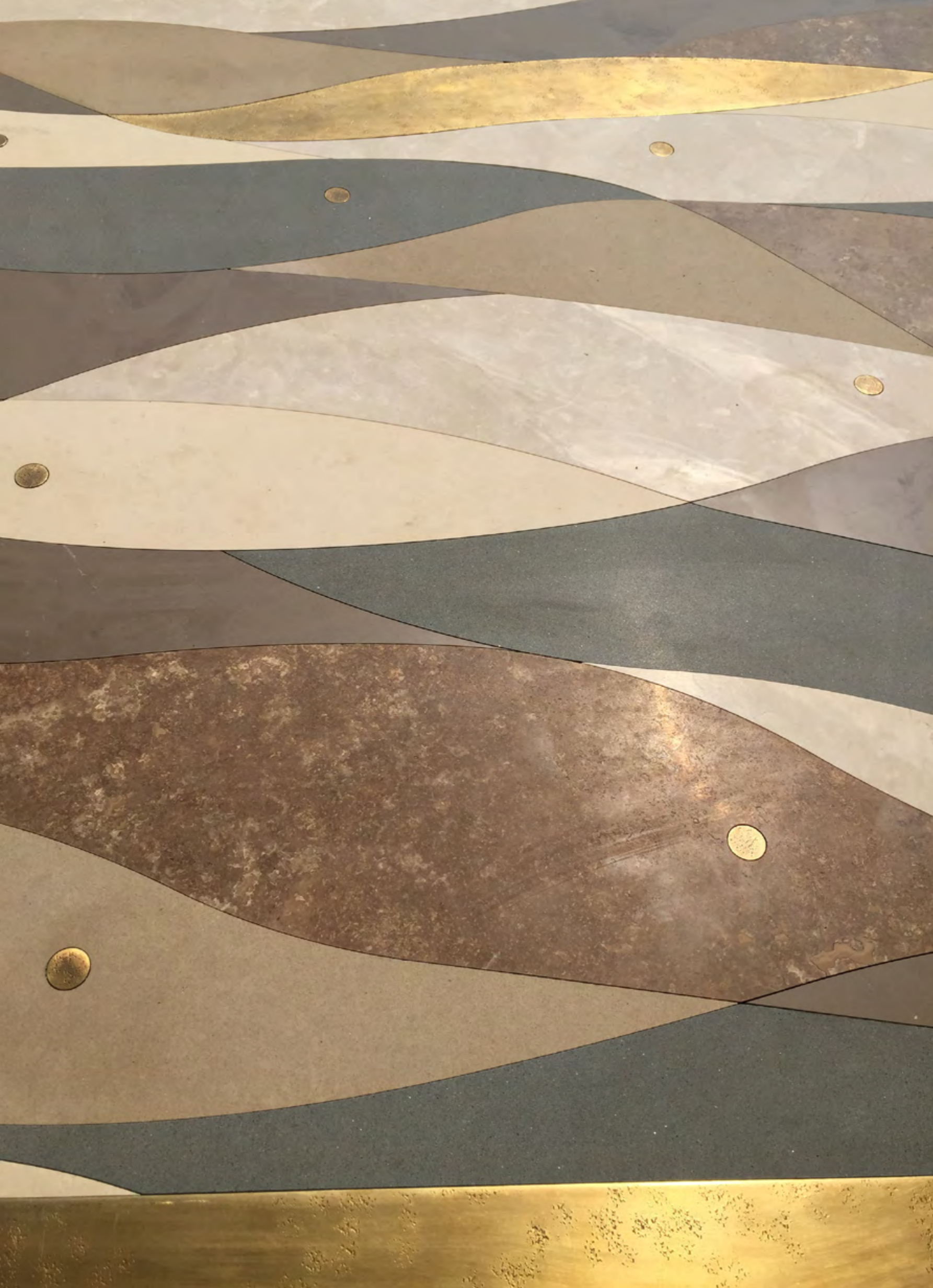

THE MURANO COLLECTION
A NEW GENERATION OF DECORATIVE SLABS

The Murano Collection Breathe new life into historical Italian materials with The Murano Collection—a fusion of heritage and innovation. This remarkable new generation of decorative slabs combines the artisan excellence of Umbrian, Tuscan, and Venetian handmade Terracotta with the timeless beauty of Murano Glass and natural stones.

The result is a breathtaking three-dimensional surface where the interplay of Murano Glass and grazing light creates a mesmerizing effect of depth and movement.

When backlit, the colours and textures are further enhanced, revealing the collection's true artistic essence.

With limitless possibilities in colours, patterns, and dimensions, The Murano Collection redefines elegance, offering a sophisticated and unparalleled design experience.

The Murano Glass, originating from the Venetian island of Murano, stands as a testament to centuries of masterful craftsmanship in decorative glassware. Venetian artisans have long been pioneers in Europe, continually innovating and refining glass-making techniques. Renowned for its vivid colours and intricate details, Murano Glass remains a symbol of exceptional artistry.

Even today, glass-makers in the Venetian region uphold this tradition by employing age-old methods to create stunning masterpieces. The Barbieri Artisans, for instance, produce exquisite 30cm x 60cm glass slabs with a 1 cm thickness, skilfully crafted and precision-cut using water-jet technology. Their expertise allows for customized glass colours, demonstrating the versatility and timeless beauty of Murano Glass.

Each fusion process results in subtle colour

variations, ensuring that no two pieces are exactly alike. These natural nuances enhance the uniqueness of every creation, reinforcing the artistic essence of Murano Glass.

The Art of Handmade Terracotta Discover the rich heritage of handmade Italian Terracotta, a craft deeply rooted in tradition. Using refined clay soils sourced from Central and Northern Italy, skilled artisans create tiles in an array of stunning colours, including light gray, black, chocolate, khaki, light beige, and a unique red, recycled from historic home renovations.

The production process begins with craftsmen shaping the clay using wooden moulds. After natural drying, the tiles undergo a meticulous 10-day firing cycle in a kiln, ensuring their strength and durability. Each piece is then hand-cut with precision, showcasing the care and expertise embedded in every creation.

Italian Terracotta represents timeless elegance, bringing warmth and character to any space.

The Barbieri Family Artisans Since 1975, the Barbieri Family Artisans have pursued perfection in an ever-evolving and captivating way, using marble as their medium. Their mastery of handmade craftsmanship, combined with Giovanni Barbieri's visionary designs, has led to the creation of an extraordinary alternative to traditional backlit onyx and semi-precious stone installations. Their concepts for walls and floors present an unmatched aesthetic, available in an infinite variety of colours, patterns, and dimensions.

The Murano Collection is designed for interior applications, with the exception of shower walls and similar high-moisture areas. These glass slabs can also be installed on tempered or stratified glass, making them suitable for smaller formats with an optional integrated LED back-lighting system.

SAINT GERMAIN

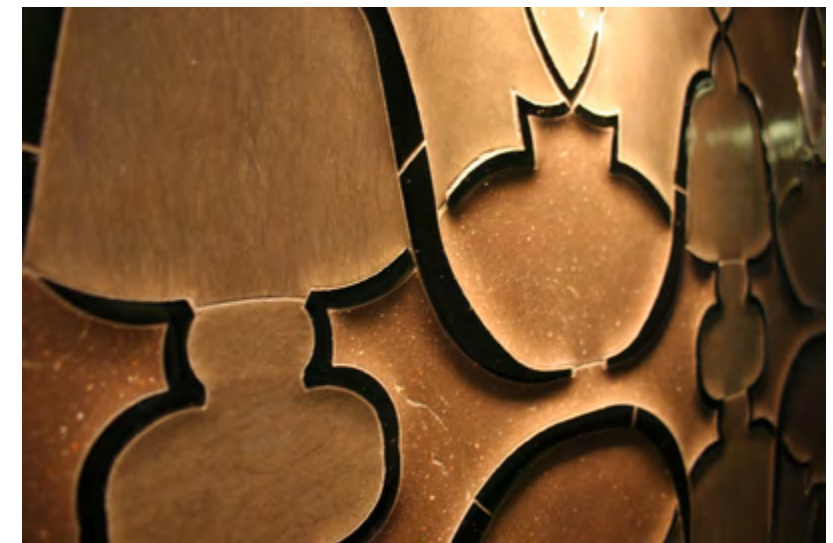
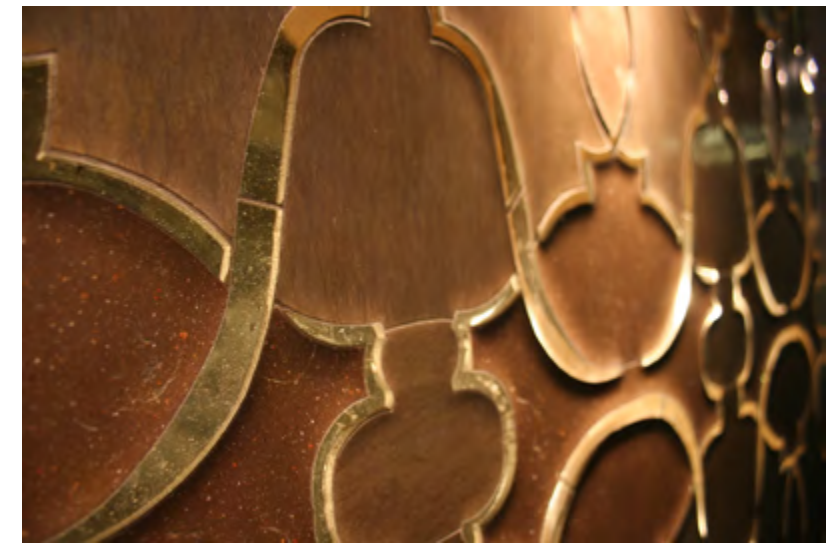

Carrara, Calacata and Thala Grey Marble with
White Silk and Opaline Murano Glass polished
relief inlay
Panel size 38" x 38"
(96 x 96 x 2 cm)
Backlit on (above), backlit off (below).



SAINT GERMAIN



Black and Grey Italian handmade terracotta with
Murano Glass polished relief inlay in dark grey
(become almost white when backlit).
Panel size 38" x 80" (96 x 200 x 2 cm)

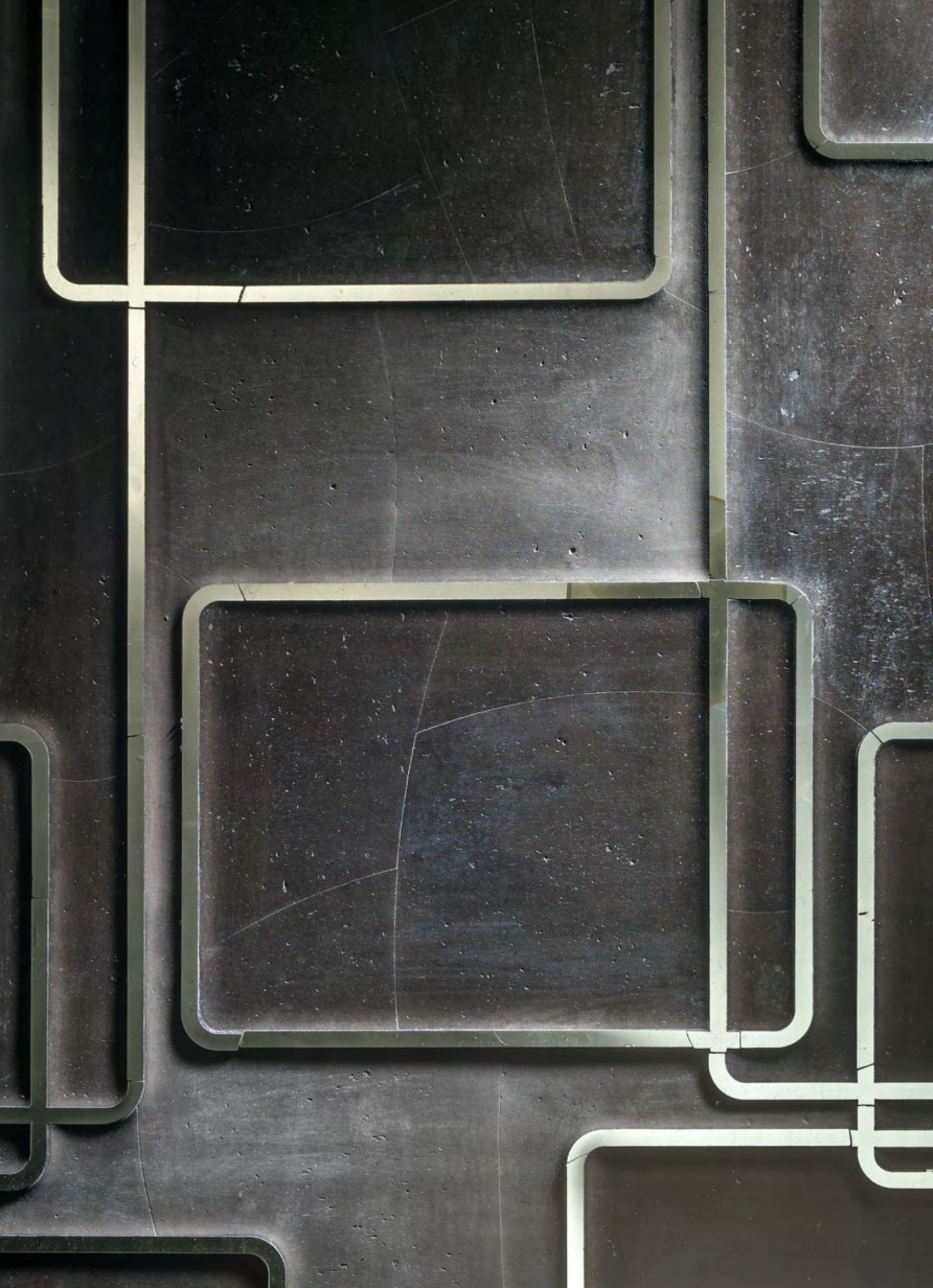

OBLIO



Grey and Black Italian handmade terracotta with
polished relief inlay in dark grey
Murano Glass (become white when backlit)
Panel size 38" x 38" (96 x 96 cm)



CLAS



15 x 25 Cm modular shapes or fit to size
Brown/Grey handmade terracotta & Foussana,
Thala Grey, Beige Avorio Marble, Dark Grey Murano
Glass that become mostly white when backlit

Mixed surface Textures Honed/ polished
Panel size 38" x 38" (96 x 96 x 2 cm)

HEX

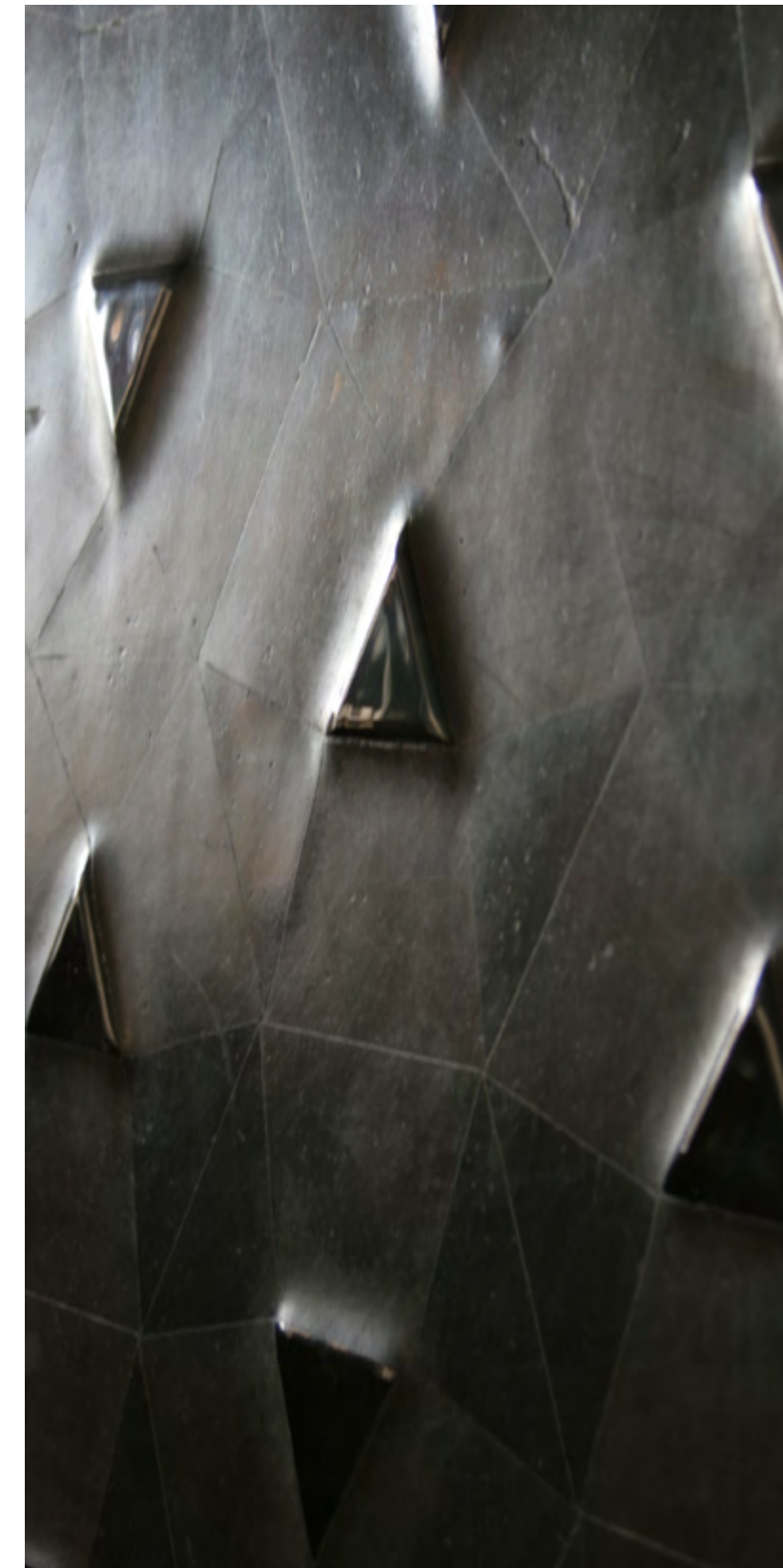

Grey and Black Italian handmade terracotta with
polished relief inlay in dark grey
Murano Glass (white when backlit)
Panel size 38" x 38" (96 x 96 cm)



SIN BLUE



Black Italian handmade terracotta with Blue Cobalt
& Dark Grey Murano Glass polished relief inlay
Panel size 38" x 38" (96 x 96 cm)

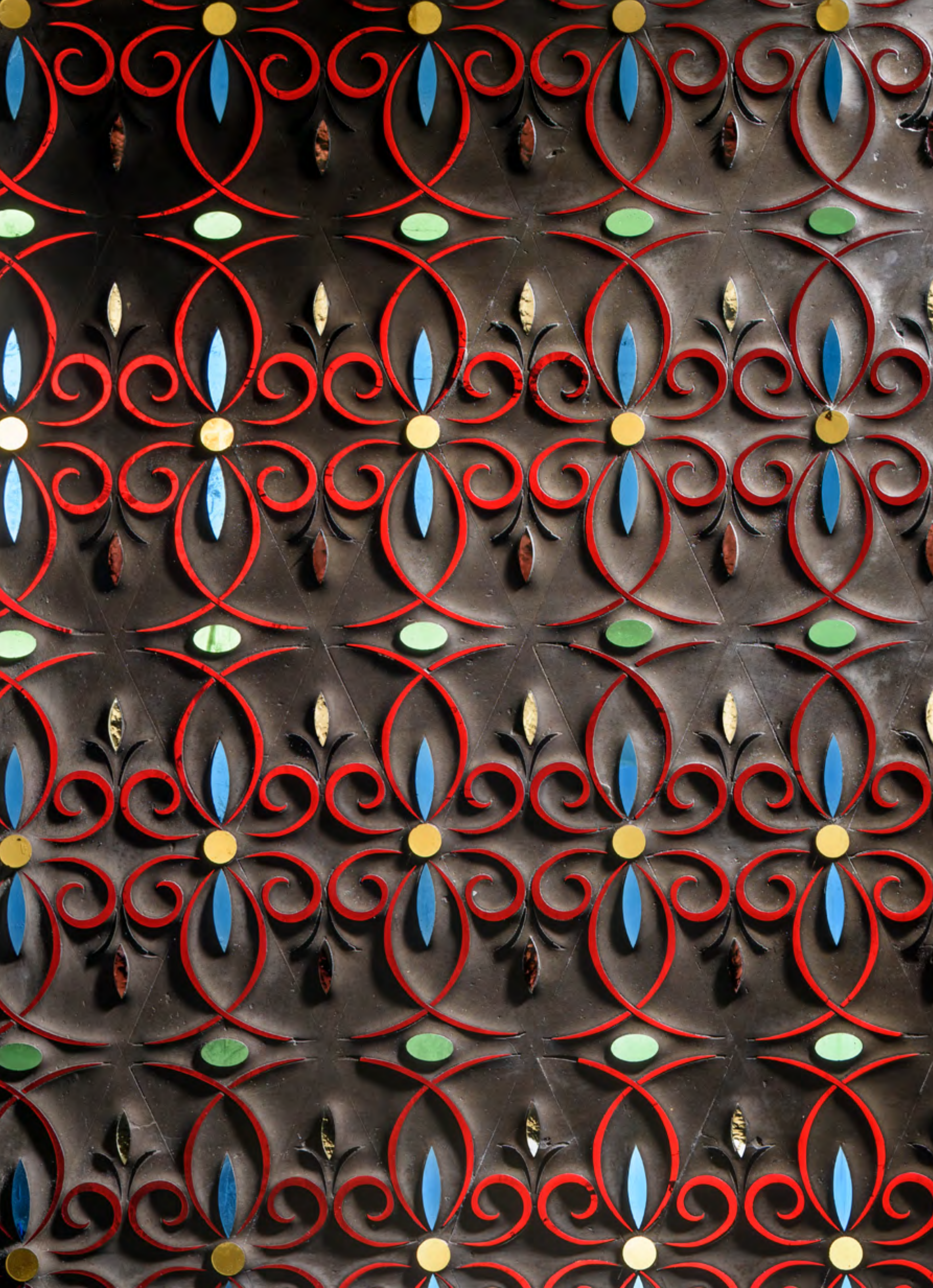

TEFI



Grey Italian handmade terracotta, with 8 different
Murano Glass polished relief inlay
Panel size 38" x 38" (96 x 96 x 2 cm)



HERAMOSA



Red Travertine,
Red reclaimed venetian handmade terracotta,
amber Murano Glass polished relief inlay with gold
leaf dot Insert
Panel size 38" x 38" (96 x 96 x 2 cm)
Below: Backlit. Lighting enhances the surface
relief.



NOTREDAME



Light Beige / Khaki handmade terracotta, Avorio
Marble with White Silk Murano Glass polished relief
inlay
Panel size 38" x 38" (96 x 96 x 2 cm)
Full backlit.



MILAN FLOREAL



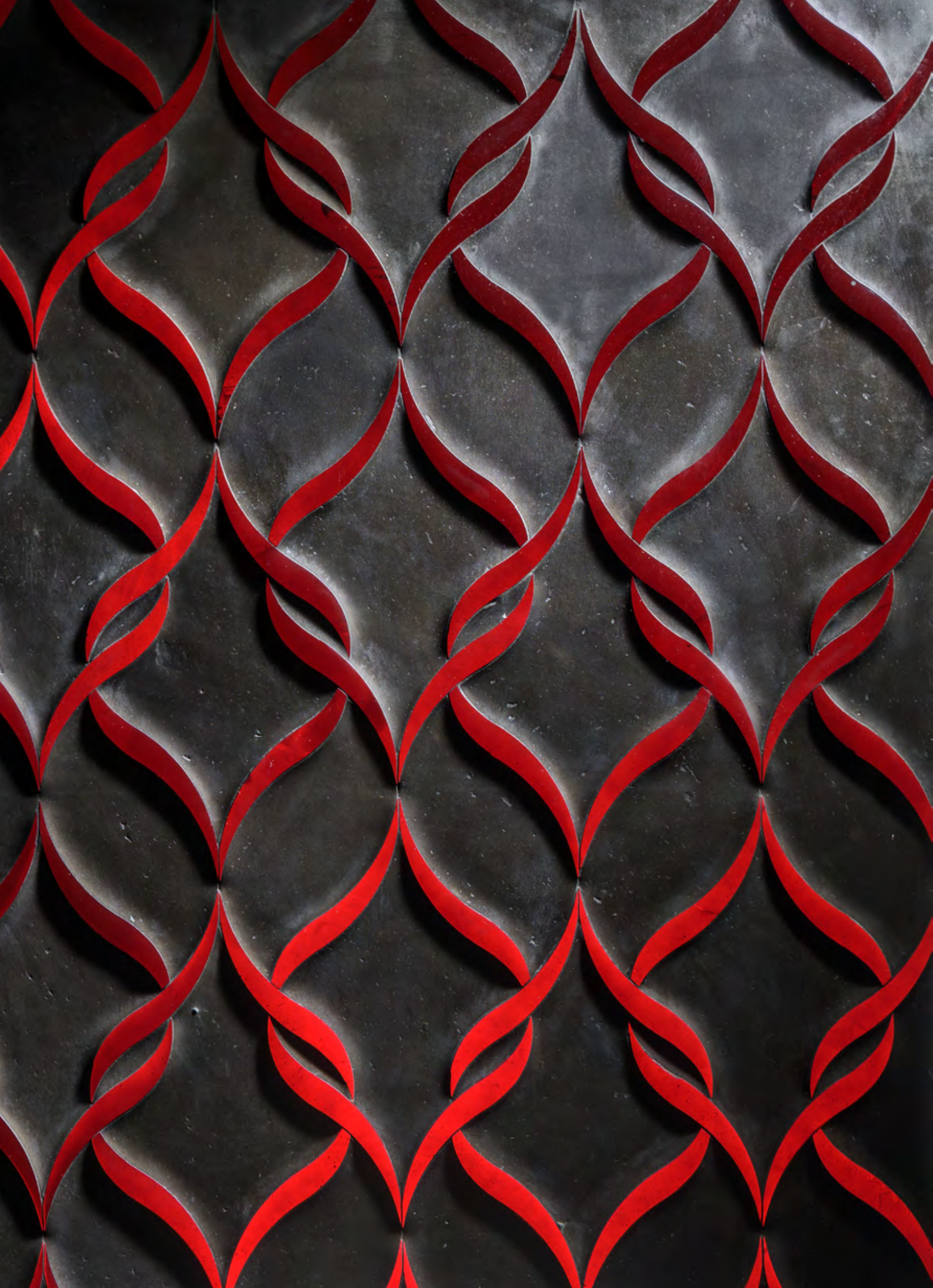

SOPHIE



Grey Italian handmade terracotta, with polished relief inlay in transparent Glass and silver leaf applied on the bottom on each single piece/

Red Rubin Murano traslucent glass polished reliefs inlays , partially backlit, on the left page.
Full height of panel size 38" x 38" (96 x 96 cm)
Design by Sara Baldwin

B L O O M I N G
THE FIRST DIFFERENT
FLORAL PARQUET SYSTEM ON EVERY BLOOM



reddot winner 2023
best of the best



reddot winner 2023
materials and surfaces design





Parquet is reinvented with Blooming, the innovative floral pattern design created by Giovanni Barbieri. A poetic encounter between the delicacy of a bouquet of flowers and the materiality of wood that renews the way of thinking about wooden surfaces. Blooming expresses a new aesthetic and functional concept of parquet: 48 sinuous and distinct oak “petals,” available in 3 different shades, harmoniously come together in floors that become striking floral compositions, with a strong material expressiveness. Sophisticated “blooms” come to life with each laying, through shapes that are never

the same but always well-coordinated, combining the brilliance of a creative and novel idea with ease of installation.

Industrially manufactured and cut, the individual wood elements are meticulously beveled and can be freely positioned to create a different, striking final look each time, thanks to a simple and intuitive laying system. Blooming thus revolutionizes the traditional concept of parquet, combining the luxury of the uniqueness of a custom-designed floor with the practicality and convenience of industrial production.



COLORS AND DIMENSIONS

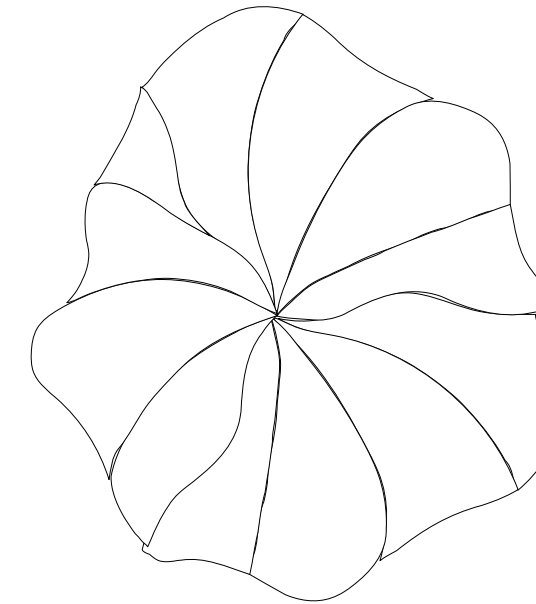

0.22 sq. m (2.40 sq. ft.)

1 set of few different models = 0.89 sq. m (9.6 sq. ft.)

Total thickness is 5/8 inch (15 mm),
featuring a 3 mm hardwood top layer

All shapes are beveled for a refined finish, ensuring a simple and self-explanatory installation system. The flooring is suitable for heated floors and requires full surface bonding for optimal durability.

Each piece is crafted with a plywood birch support, using vinyl glue on a 3 mm hardwood layer. The standard thickness is 5/8 inch (15 mm), comprising 3 mm hardwood and 12 mm birch plywood, with custom thicknesses and surface finishes available based on quantity.

The flooring must be glued down and not installed as a floating system. Special half-straight cut pieces are available to facilitate precise main wall installation starts.

The design is copyrighted at copyright.gov, and the process to create the Blooming Design is patent pending at USPTO.



Pattern #1
Oak



Pattern #2
Oak natural
Oak 120°
Oak 157°



Pattern #1
Oak natural



Pattern #1
Oak 120°

ARTWORK

IN COOP. WITH ROBERTO LANARO METAL SCULPTOR



“Sinuosity Dots”
24” x 24” x 3/8 (61 x 61 x 1 cm)
Brass and natural Stone handmade
12 pieces Limited Edition



“Core”
Diameter 24” x 3/8 (61 x 1 cm)
Brass and natural Stone handmade
2 pieces Limited Edition



“Conjunction”
24”x 24”x 3/8 (61 x 61 x 1 cm)
Brass and 8 different yellow-beige
Natural Stone
12 pieces Limited Edition

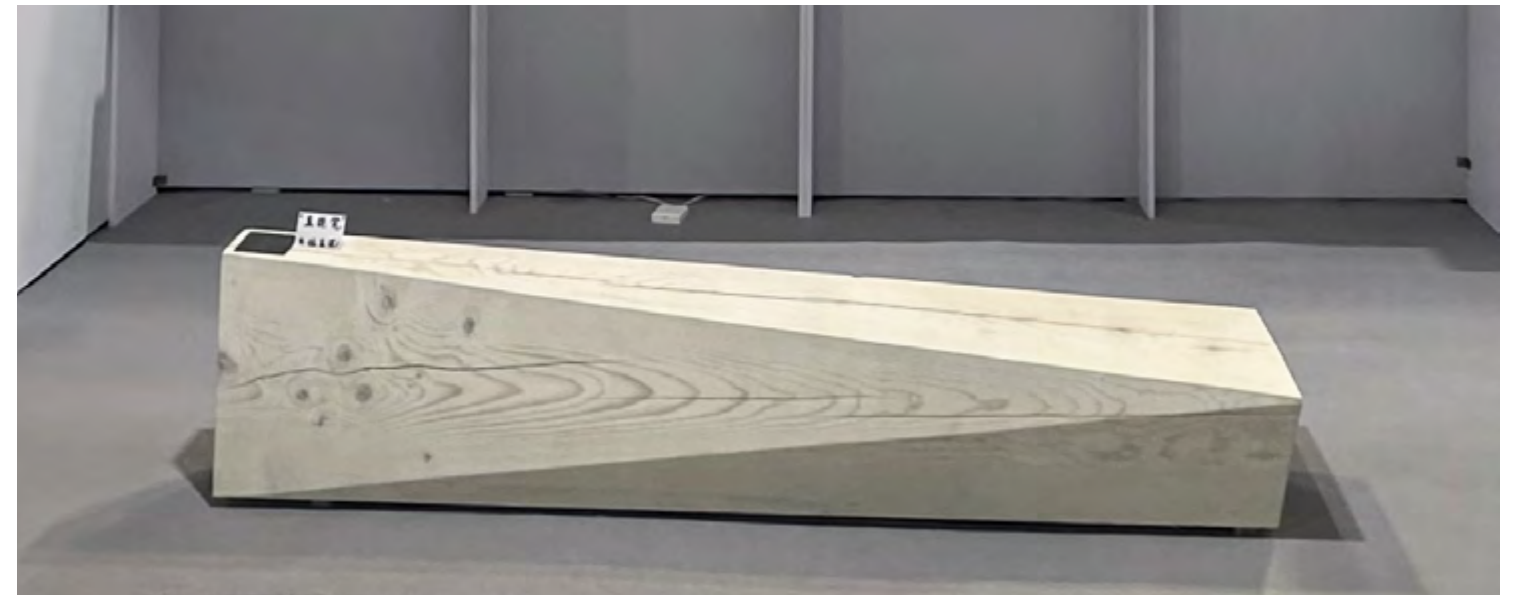

“Straight” bench is an uncomfortable seating long just enough to let you speak “straight,” which is the solid and only what we all needs.

“The ‘Straight bench’
Finland 110-125 year old solid spruce wood
Single size available : 205 x 43 x 50 cm
(6’ 5” x 17” x 20”)

4 Pieces limited edition.

A W A R D S

